

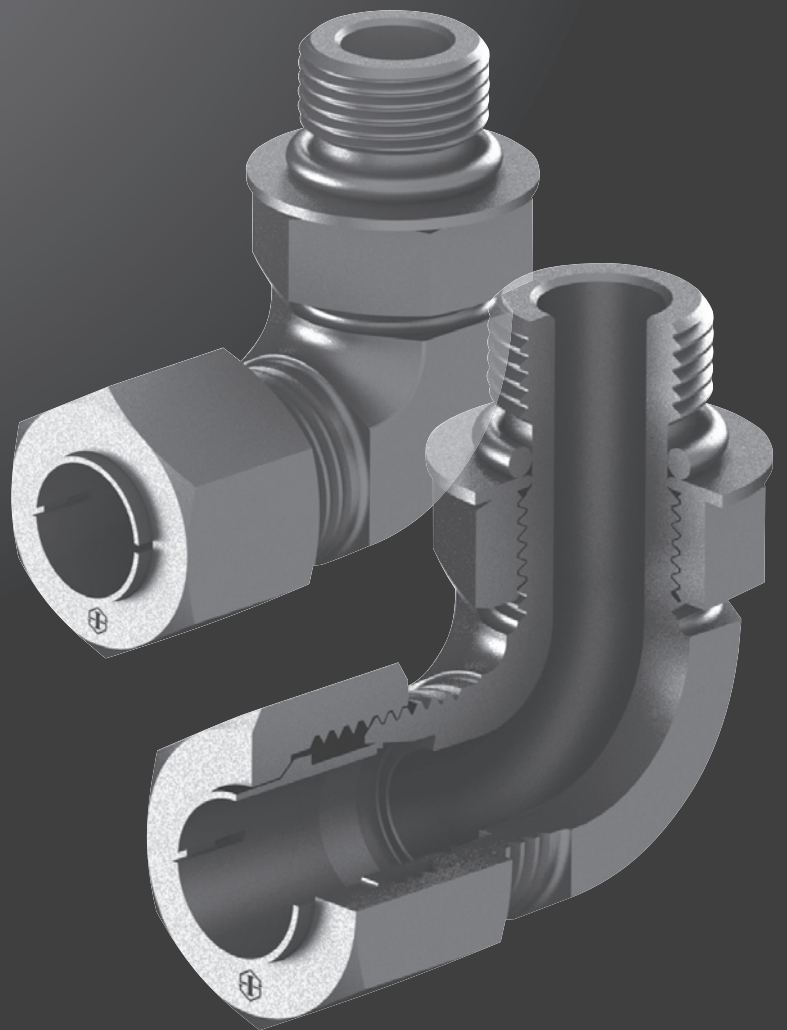

IHARA

耐振継手 NE形鋼管用くい込み継手

NE Bite Type Tube Fittings



イハラサイエンス株式会社
IHARA SCIENCE CORPORATION

鋼管用くい込み継手 / BITE TYPE FITTINGS FOR STEEL TUBES

1. くい込み継手の特長 / FEATURES OF BITE TYPE FITTINGS

- (1) 配管のためのねじ切り、溶接、フレア加工、ろう付などを必要とせず、配管工数を低減できます。
 - (2) ねじ切り、溶接を必要としないため管を薄肉にでき（くい込み継手の機構および管の剛性から管肉厚は、その外径寸法の10%以上、外径φ10mm以下の場合には最小1mm必要です）、曲げ加工も容易となるため継手使用総数も少なくなり、機器の軽量化・コンパクト化がはかれます。
 - (3) 分解・再組立てをくり返し行っても完全な接続が確実に再現できます。
 - (4) Oリングなどのシール材を用いないメタル接触シールのため、広い温度範囲にわたって使用できます。
 - (5) 使用流体・外部雰囲気等に応じて、炭素鋼・ステンレス鋼・黄銅など適切な継手材質を選ぶことができます。
- (1) Bite type fittings do not require threading, welding, flaring nor brazing to perform piping and substantial man hour saving can be realized.
 - (2) Without requiring threading nor welding, thin wall tubes can be used for piping (tube wall thickness are required to be more than 10% of the tube outside diameter due to bite type fitting mechanism and rigidity of the tube, however, the minimum thickness must be more than 1 mm). Thin wall tubes facilitate bending and enable reducing the number of fittings which will contribute to decrease the weight of the equipment as well as permit compactness.
 - (3) Even after repeated disassembly and remake, the connection made is both integral and reliable.
 - (4) Sealing being achieved by metal contact without involving sealing material such as O-ring, application over wide temperature range is feasible.
 - (5) Fitting material can be selected from carbon steel, stainless steel, brass and other metal to adapt to the conditions of application such as fluid to be handled and the external environment.

2. くい込み継手の機構 / BITE TYPE FITTING MECHANISM

くい込み継手は本体・ナット・スリーブの3つの部品から構成されており、所定の手順により正確に締付けられたとき、図に示すようなくい込み状態が得られます。

- ①スリーブのカッティングエッジは管に食い込み、管を保持すると共にスリーブと管との間のシールをします。
- ②スリーブの外周面は継手本体のテーパ面に圧着し、スリーブと継手本体との間のシールをします。
- ③スリーブのわん曲は強力なばね作用として働き、長期間にわたりシール性能を維持すると共に、振動等によるナットのゆるみを防止します。
- ④スリーブの後部は管外周に圧着し管を保持すると共に、振動等によるくい込み部への応力集中を緩和します。

このような機構により、くい込み継手は衝撃・振動等をともなう配管においても高圧流体を完全にシールします。

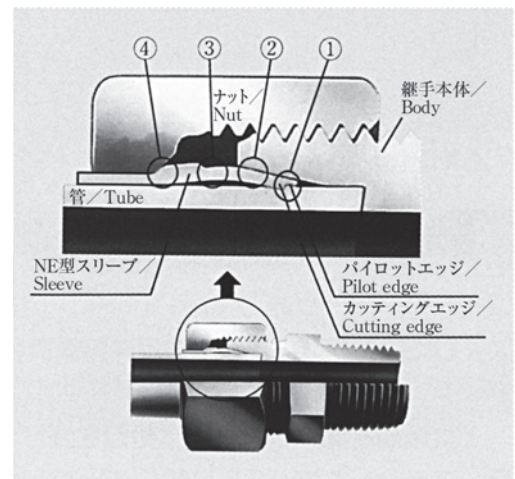

The bite type fitting consists of 3 components, namely, the body, the nut and the sleeve, and by properly assembling the components and tightening in accordance with the specified procedure, the sleeve will bite into the tube as illustrated in the figure.

- ①The cutting edge of the sleeve will bite into the tube to firmly hold the tube and at the same time performs sealing between the sleeve and the tube.
- ②The outer periphery of the sleeve is tightly pressed along the tapered bore surface of the body and performs sealing between the sleeve and the body.
- ③The bowing action of the sleeve works as a powerful spring and maintains sealing function over a long period of time as well as prevent the nut from becoming loose by vibration.
- ④The rear portion of the sleeve is compressed against the outer periphery of the tube and holds the tube as well as relieve stress concentration from vibration to the part where the sleeve bites in to the tube.

The mechanism of the bite type fitting as explained above enables the fitting to completely seal high pressure fluid even where the piping undergo impact, vibration, etc.

3. エンベロープ付スリーブの特長 / FEATURES OF SLEEVE WITH ENVELOPE

- (1) スリーブのエンベロープ部により配管の芯出しが厳密にでき、従来油漏れの原因となっていた芯ズレによるトラブルが大幅に減少します。
- (2) スリット付きのエンベロープ部により耐振性能が向上。従来のNS形くい込み継手に比べ、疲労強度が20%以上向上しています。これにより配管振動による管の破損、ナットの緩みが減少します。
- (3) NS形くい込み継手と本体との互換性がありますので、既設配管の改造・補修も容易です。

従来形くい込み継手において、締付けにより管に発生する応力は図-2に示す分布を呈しております。外部振動、圧力変動等により配管に振動が加わる時、繰り返し曲げ応力が発生し管折れを起こすことがあります。この管折れは、主に疲労破壊であり、スリーブの後端部（図のA部）に多く発生することが確かめられています。

NE形くい込み継手では、この締付け時に発生するA部の初期応力の分散・緩和を狙い、スリーブの後端にスリット付きのエンベロープ部を設けております。この結果、応力分布は図-1に示す通り改善され、疲労強度が向上しております。

- (1) The envelope of the sleeve enables strict centering of the piping and contributes to substantially reduce the number of the off-centering which has been the major cause for leakage in piping.
- (2) The slits on the envelope have enhanced the capability to resist vibration. Fatigue strength has been increased more than 20% in comparison to the conventional NS type bite type fittings. This contributes to reduce the number of failures due to tube damage and loosening of the nut caused by tube vibration.
- (3) The body of NE type fitting are interchangeable with NS type fitting body which facilitates making improvements and repairs of existing piping.

With conventional type of bite type fittings, stress distribution to the tube will generate as shown in Figure 2 when tightened.

Repeated bending stress will generate when vibration originating from external vibration, pressure fluctuation, etc. is applied to the piping and can eventually lead to a breakage in the piping.

It has been ascertained that this piping breakage is caused mainly by fatigue failure, and is concentrated mainly at the rear edge of the sleeve (part "A" in the drawing) .

With the NE type bite type fitting, sleeve having envelope with slits on the rear edge has been employed to dissipate and relieve the initial stress at "A" point that generates when the fitting is tightened.

This has improved the stress distribution as shown in Figure 1 and enhanced strength against fatigue.

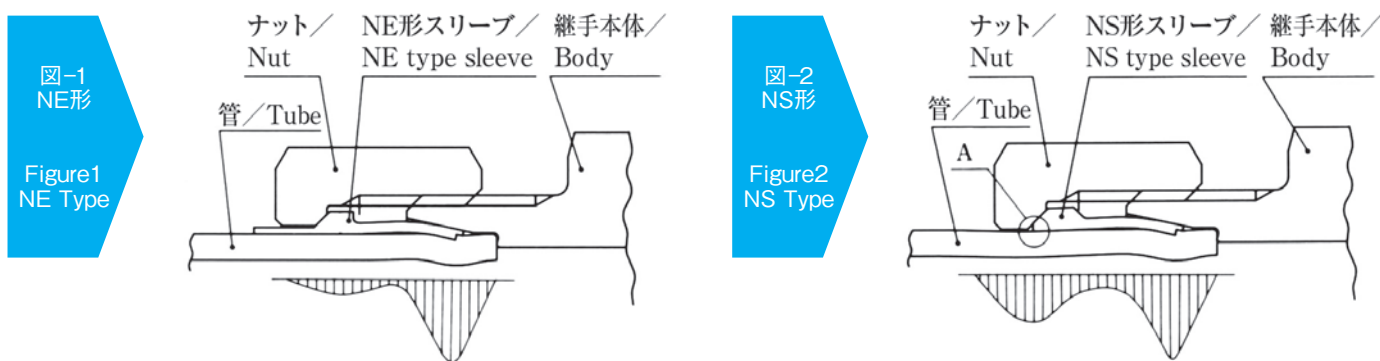

4. 適用する管 / TUBE SELECTION

このカタログの継手類に適用する管は主として次のものがありますが、とくに下記 (1)、(2)、(6) の鋼管が適合しますので、このご使用を推奨いたします。

- (1) JIS B 2351 油圧用 25MPa {250kgf/cm²} くい込み式管継手 付属書 くい込み式管継手用精密炭素鋼鋼管：STPS各種
- (2) 日本フルードパワー工業会規格JOHS-102油圧配管用精密炭素鋼鋼管：OST各種
- (3) JIS G 3454 圧力配管用炭素鋼鋼管：STPG370
- (4) JIS G 3455 高圧配管用炭素鋼鋼管：STS370
- (5) JIS G 3456 高温配管用炭素鋼鋼管：STPT370
- (6) Eチューブ油圧配管用炭素鋼鋼管電縫管 (当社規格品)
- (7) JIS 3459配管用ステンレス鋼鋼管に規定するSUS304TP SUS316TP

⚠注意：上記(3)(4)(5)(7)は、冷間仕上継目無鋼管で表面硬さHRB80以下のものをご使用ください。

Tubes that are mainly applicable for use with the fittings are listed below, and steel tubing of (1), (2) and (6) are particularly adaptable and recommended for piping application with these fittings.

- (1) JIS B 2351 Pipes for oil hydraulic service 25 MPa (250 kgf/cm²), STPS standard pipes for bite type tube fitting:
- (2) Japan Oil Hydraulic Industrial Society Standard JOHS-102 Precision carbon steel tube for oil hydraulic piping : OST various types
- (3) JIS G 3454 Carbon steel pipes for general service: STPG 370
- (4) JIS G 3455 Carbon steel pipes for high pressure service: STS 370
- (5) JIS G 3456 Carbon steel pipes for high temperature service: STPT 370
- (6) Electric-resistance-welded carbon steel tube for E tube oil hydraulic piping (in-house standard)
- (7) SUS 304TP and SUS 316TP specified in stainless steel piping for JIS 3459 piping

⚠CAUTION: In case of using (3), (4), (5) and (7) above, select ones which are cold finished seamless pipes with surface hardness less than HRB 80.

5. 標準仕様 / STANDARD SPECIFICATION

管継手の大きさ (適用する管の呼び) Fitting sizes (Applicable nominal tube)	ミリメートル管用 (チューブ) For mm tube	4~8	10~15	16~25	28~30	35~38	40~50
	スケジュール管用 (パイプ) For schedule pipe	1/8・1/4	3/8・1/2	3/4		1	1-1/4・1-1/2
定格圧力 Rated pressure	MPa	50	40	31	28	25	21
温度範囲 Temperature range	℃	-20~+250℃					

⚠警告：

仕様値を超える使用方法はしないでください。

⚠注意：

定格圧力及び温度は、くい込み接続のみの仕様です。アダプターなどは他の接続方法の仕様、条件も考慮し選定下さい。

⚠WARNING：

Use in excess application is forbidden.

⚠CAUTION：

The rated pressure and working temperature range stated above are the specification for bite type connection only. Other connection such as adapter shall be selected considering other specification and conditions.

6. 材質 / MATERIAL

(1) 本体及びナット / Body and Nut

JIS G 4051 機械構造用炭素鋼鋼材 S25C~S48C又はこれと同等の性能を有する材料

JIS G 4051 Carbon steel material for machinery structure 25C~S48C or material equivalent.

(2) スリーブ / Sleeve

炭素鋼を用い、表面硬化処理を施行

Carbon steel with surface hardened.

(3) ステンレス鋼 (SUS304、SUS316) の指定にも対応いたします。

Stainless steel (SUS304 and SUS316) is also available.

7. 呼び記号と標準サイズ / PART NUMBERS (NOMENCLATURE) AND STANDARD SIZES

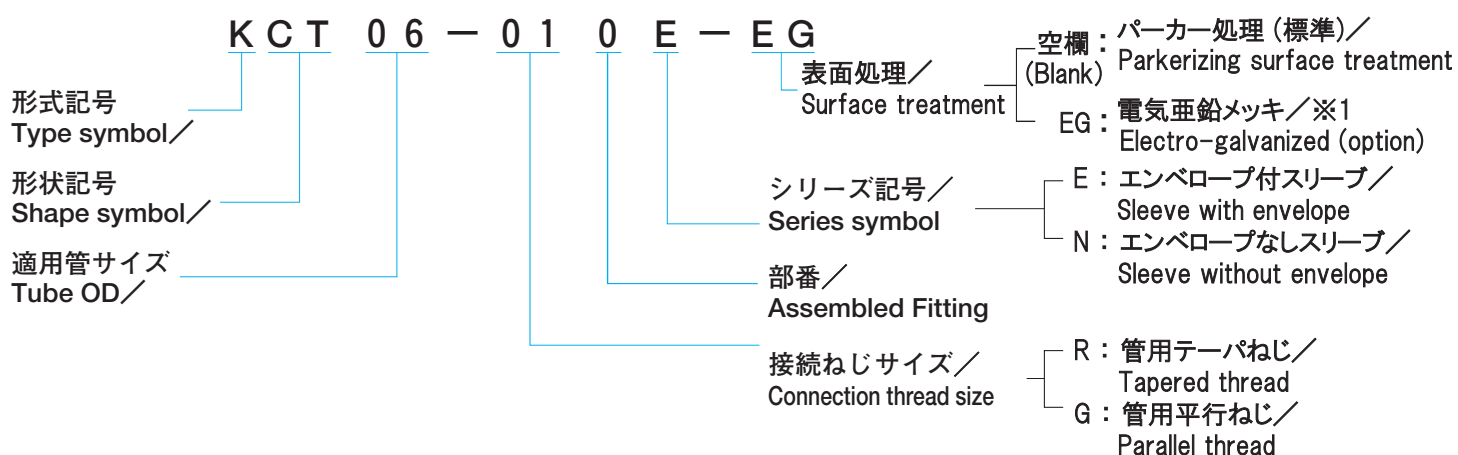

※1 スリーブはパーカー処理を行います。スリーブも電気亜鉛メッキを御希望の場合は、型番末尾に「KO-EG」とご記載下さい。
Standard sleeve is parkerized surface treated, and upon request sleeve with electro-galvanized can be supplied, in which case, please add "KO-EG" to the end of the part numbers.

(例) KCT06-010E-EG KO-EG

Example) KCT06-010E-EG KO-EG

ミリメートル管 (チューブ) mm tube	外径寸法 OD size	4	6	8	10.....30.....50				
	呼称記号 Nominal size	04	06	08	10.....30.....50				
スケジュール管 (パイプ) Schedule Pipe	呼び径 (B) Nominal diameter (B)	1/8	1/4	3/8	1/2	3/4	1	1 1/4	1 1/2
	外径寸法 OD size	10.5	13.8	17.3	21.7	27.2	34.0	42.7	48.6
	呼称記号 Nominal size	11	13	17	21	27	34	43	48

接続ねじ Connection thread	1/8	1/4	3/8	1/2	3/4	1	1-1/4
呼称 Nominal size	01	02	03	04	06	08	10

⚠ 警告:

くい込み継手の各部品 (本体、ナット、スリーブ) は、他社製品との混用はしないでください。
継手の性能が充分発揮できず重大事故につながる可能性があります。

⚠ WARNING:

The intermixing use of bite type fittings parts (body, nut, sleeve) with other company's is forbidden.
Because fittings don't function properly and may cause the serious accident.

8. 防錆処理 / RUST-PROOFING TREATMENT

パーカー処理を標準と致しますが、ご要望により各種表面処理を行います。

Parkerizing is standard surface treatment, but upon request other types such as Electro-galvanized can be applied.

9. ご注文について / WHEN ORDERING

- (1) ご注文の際は、管継手の呼び記号をご指示ください。
- (2) 本カタログ記載以外のものも別途設計・製作いたします。仕様をご明示のうえお問い合わせください。
- (3) 径違い継手のお問い合わせ・ご注文は下記要領にてお願いいたします。

- (1) When ordering, specify parts numbers of fittings.
- (2) In addition to the fittings listed in this catalog, special design fittings can be produced. Please inquire specification case by case.
- (3) When the fitting has different size ends, order as follows:

鋼管用くい込み継手径違いティー
Fitting with three different size end

※誤認防止のため、右記の略号を用いてください。
※To preclude ordering error, use symbol as right.

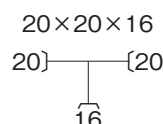

なお、径違い継手の大きさの呼び方は次によります。

- (イ) 2個の口径をもつ場合
径の大きなものを①、小さなものを②とし、①②の順序で呼ぶ。
- (ロ) 3個の口径をもつ場合
同一または平行な中心線上にある径のうち大きなものを①、
小さなものを②、残りのものを③とし、①②③の順序で呼ぶ。

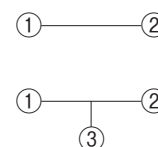

For fitting with different size end, call out as follows:

- a. Two the different size ends
With the larger size end as① and the smaller end as② call out in the order of①, ②
- b. Three different size ends
With the larger size end on the same center line as① and the smaller size end as② and the remaining end as③, call out in the order of①, ②, and③.

10. その他 / Others

このカタログに掲載の仕様および外観は、改善のため予告なく変更することがありますのでご了承ください。

Ihara Science Corporation reserves the right to make changes to the specifications and the general appearance of the products of this catalogue without prior notice in order to implement improvements.

11. 締付け手順 / TIGHTENING PROCEDURE

くい込み継手の性能を十分に発揮させるためには、適切な管の使用と継手の正確な締付けが必要です。くい込み継手は配管場所で直接締付けることもできますが、以下に述べる予備締付け（プリセット）を行うことにより、配管作業が円滑かつ確実に行えます。

ご使用にあたり、取扱説明書をお読みください。

It is imperative that proper tubes are selected and the fittings are correctly tightened for the bite type fittings to fully exhibit it's function. Bite type fittings can be directly installed and tightened at the job site, but by performing presetting as explained below the piping operation can be performed smoothly and reliably.

It is recommended to carefully peruse the instruction manual before using.

(1) 予備締付け (プリセット) / Presetting



管は所定の長さに、直角に切断します。

Cut the tube to the required length at a right angle.

⚠ 注意：管端の切断角度は $90^\circ \pm 1^\circ$ 以内を目安に切断してください。

⚠ CAUTION: Right angle of cut end should be within $90^\circ \pm 1^\circ$.

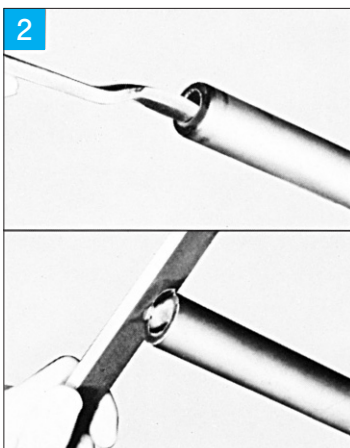

管端内外面のバリをとります。この時、管を偏平させたり外面に深い傷を付けないようにご注意ください。

Remove all burrs from the inside of cut end.

Exercise care not to deform the tube or cause damages such as deep scratches on the outside surface.

⚠ 注意：管表面には深さ0.1mm以上のキズをつけないようにしてください。

⚠ CAUTION: Handle with care to prevent scratches of more than 0.1 mm depth on the tube surface.

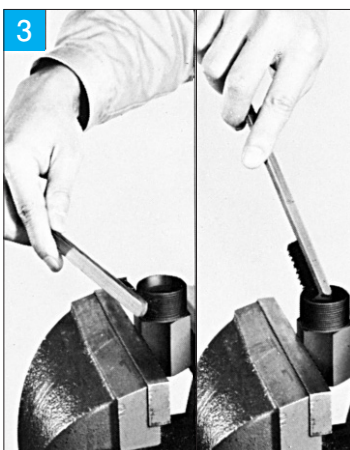

締付治具：PJAをバイスに固定し、ねじ部・テーパ部に塗油します。

Firmly clamp the tightening jig PJA in a benchvice. Lubricate threads and tapered surface of the bore.

⚠ 警告：治具はバイスに確実に固定してください。

⚠ WARNING: The jig must be firmly held in the vice.

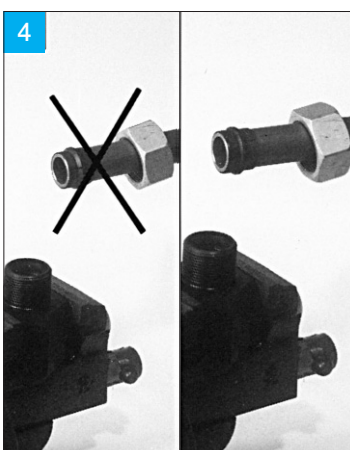

ナット・スリーブの順序・方向をまちがえないように、管へ挿入します。

Insert the nut first and the sleeve with correct direction on to the tube.

⚠ 警告：特にスリーブの方向に注意してください。

逆に挿入しますと管へのくい込みが得られず管抜け事故の原因となります。

⚠ WARNING: Pay particular attention to the direction of the sleeve. If inserted in the reverse direction, the sleeve can not bite into the tube and result in tube pulling out.

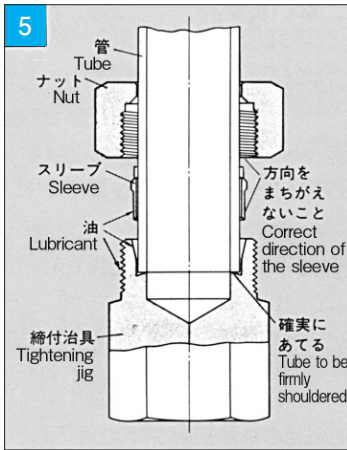

ナット・スリーブを挿入した管を締付治具に差し込みます。

Insert the tube with the nut and the sleeve into the tightening jig.

⚠ 警告：管端は管突き当て部に確実に当ててください。

管端が管突き当て部より浮いた状態で締付けますと充分なくい込み状態が得られず管抜け事故の原因となります。

⚠ WARNING: The tube must be inserted until the tube end firmly bottoms on the fitting body shoulder. If the nut is tightened with the tube end not contacting the shoulder, the sleeve will not adequately bite into the tube and result in pulling out of the tube.



ナットを指で締めます。

Tighten the nut fingertight.

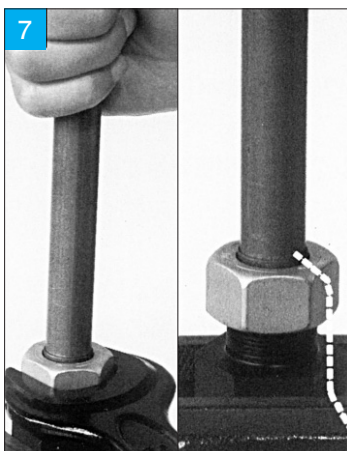

グリップポイントを確認します。

管を軽く回しながらナットを締付けてゆくと、管が回らなくなる点があり、この点をグリップポイントといいます。この時、スリーブが管に食い込み始めます。次の最終締付け量を確認するため合マークをつけます。

Determine the grip point.

While turning the tube lightly with the fingers, tightened the nut until the point is reached where the tube can no longer be turned. This point is referred to as the grip point. It is at this point that the sleeve starts to bite into the tube. Draw identification matching mark so that the amount of tightening can be determined.



グリップポイントから1-1/4回転ナットを締付けます。但し、チューブエンド形状を持つ継手で溝加工のされたKRE、KHA、KHB、KHC、KHO、KAPは手締め位置（写真⑥）より1-3/4回転ナットを締付けます。以上でスリーブは管に完全に食い込みます。

Tighten the nut 1-1/4 turns with a spanner from the grip point. However for the types of KRE, KHA, KHB, KHC, KHO, KAP which are fittings with tube end configuration with grooves, the tightening from the finger tightened position (photo 6) should be 1-3/4 turn. With the above procedure the sleeve has been firmly seated into the tube.

⚠ 警告：ナット締め付けの際は足場を確保し、周囲の安全を確認してください。又、スパナはナットに確実に差し込んでください。

⚠ 注意：締め不足は漏れや管抜けの原因となります。又、過剰な締め付けは、継手を損傷し機能を損なう恐れがあります。

⚠ WARNING: Provide adequate work space and assure safety when tightening the nut. The wrench must be properly fitted to the nut when tightening.

⚠ CAUTION: If tightening is insufficient, leakage may occur and the tube may pull out. Excessively tightening the nut can damage the fitting and impair its function.

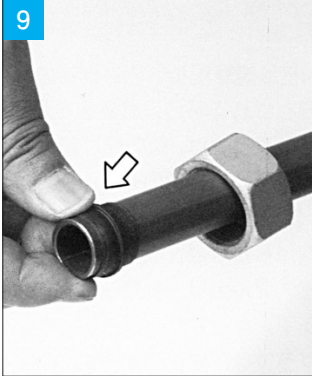

- ナットをゆるめ、スリーブをチェックします。
 イ) 管端とスリーブ端を数ミリ離れていること。
 ロ) スリーブが管の軸方向に大きく動かないこと。円周方向へ動いても差し支えありません。

Loosen the nut, and check the sleeve.

- a) The edge of the sleeve must be a few millimeters from the pipe edge.
 b) The sleeve should not move to axial direction though movement to circumferential direction is no problem.

注. 同径の管を数多く締付ける場合には、適正・確実かつ能率よく締付け作業が行える締付け装置：PSD（手動式又は油圧式）のご使用を推奨いたします。なお、PSDの操作方法等につきましては、7～11ページをご参照ください。

Note: When tightening a number of tube of the same size, it is recommended that the presetting device PSD is used to ensure proper, correct and effective tightening. Refer to page 9~14 for how to use PSD.

(2) 本締付け（リセット）／Resetting

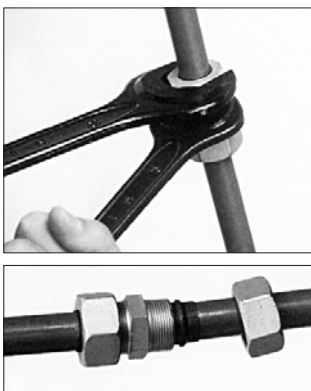

予備締付けの終わった管を継手本体に取り付け、スパナでナットを締付けて行くと急に手応えの増す点があります。この点をシャープトルクライズポイントといい、この点からさらに1/4回転ナットを締付けます。

（但しKRE、KHA、KHB、KHC、KHO、KAPのチューブエンド部分はシャープトルクライズポイントから1/6回転。）以上で配管作業は完了します。

When assembling a tube that has been presetted to a fitting body, the nut when being tightened with a spanner will reach a point where the torque will suddenly increase. This point is referred to as the sharp torque rising point. The nut is further tightened 1/4 turn from the sharp torque rising point. However, for the tube ends of KRE, KHA, KHB, KHC, KHO and KAP, tighten by turning the nut 1/6 turn from the sharp torque rising point. With the above procedures piping work is completed.

- ⚠ 警告：ナット締付けの際は足場を確保し、周囲の安全を確認してください。又、スパナはナットに確実に差し込んでください。
- ⚠ 注意：締め不足は漏れや管抜けの原因となります。又、過剰な締め付けは、継手を損傷し機能を損なう恐れがあります。
- ⚠ 注意：プリセット後のスリーブ及び継手本体のテーパ穴面は組付前にウェス・エア等で清掃してください。異物の噛み込みはシール機能を損なう恐れがあります。

注. ナットを継手本体に指締めする時、ナットがスムーズに締付けられるように管と継手の芯ズレは矯正してください。

- ⚠ WARNING: Provide adequate work space and ascertain safety when tightening the nut. The wrench must be properly fitted to the nut when tightening.
- ⚠ CAUTION: If tightening is insufficient, leakage can occur and tube may slip. Excessively tightening the nut can damage the fitting and impair its function.
- ⚠ CAUTION: After presetting, blow compressed air on the sleeve and the taper bore surface on the fitting body to remove all foreign materials before assembling. If a foreign material becomes caught, the sealing function can be impaired.

Note: Correct the centering of the tube and fitting so the nut can be smoothly tightened to the fitting body.

(3) 分解・再締付け／Disassembly

くい込み継手は、ナットをゆるめるだけで分解でき、分解後の再締付けを、前述(2)本締付け(リセット)と同一要領で行えば、8回以上の分解・再締付けが可能です。

The bite type fitting assembly can be disassembled simply by loosening the nut. When remaking is done in accordance with above mentioned resetting procedure (2), disassembly and remaking can be satisfactorily repeated more than 8 times.

- ⚠ 警告：加圧状態での着脱は非常に危険ですので絶対にしないでください。
- ⚠ WARNING: Installing and disassembling under pressure is extremely dangerous and must be prohibited.

12. NE形鋼管用くい込み継手の締付トルク（参考値）／

Tightening torque of NE type bite type fittings for steel tube (reference values)

NE形鋼管用くい込み継手の締付は、ナット回転数によるのが最適であります。締付トルクを管理の目安とされる場合、概略値を示すと下のグラフのようになります。

このグラフは、管の呼び径と継手ナットの適正締付トルク（リセットトルク）との関係を示すもので、予備締付けをPSD-S、B（予備締付装置S形及びB形）で行い、シャープトルクライズポイントから1/4回転のナット締付けを目安に選定したものです。締付トルクは、使用される管の肉厚、かたさなどの違いや、実配管での管の芯ずれ、あるいは継手を酸、アルカリ、洗浄油などにより洗浄して使用される場合、継手を再使用する場合（皮膜の潤滑効果の低下）などで変化いたします。

グラフは、表に示す管について作成したもので、継手は標準仕様品を使用しました。

再組立の場合前回締付トルクより若干高目のトルクとなります。

The optimum method of tightening NE type bite type fittings for steel tube is by the number of turns of the nut, but when tightening is to be controlled by the tightening torque, the approximate tightening torque values are as shown in the graph below. This graph shows the relation between the nominal tube size and the proper tightening torque (resetting torque) of the fitting nut.

After preliminary tightening with PSD-S or PSD-B (preliminary tightening device S type and B type), further tighten the nut 1/4 turn from the sharp torque rise point as a guideline. The tightening torque will differ with the wall thickness of the tube, tube hardness, off-centering during piping operation, fittings cleaned with acid, alkali, washing fluid, etc., and when reusing of fittings (reduction of lubrication film effect). The graph has been prepared for tubes shown in the table and the fittings are standard specification fittings. When remaking, the torque to be applied should be slightly higher than the previous tightening torque.

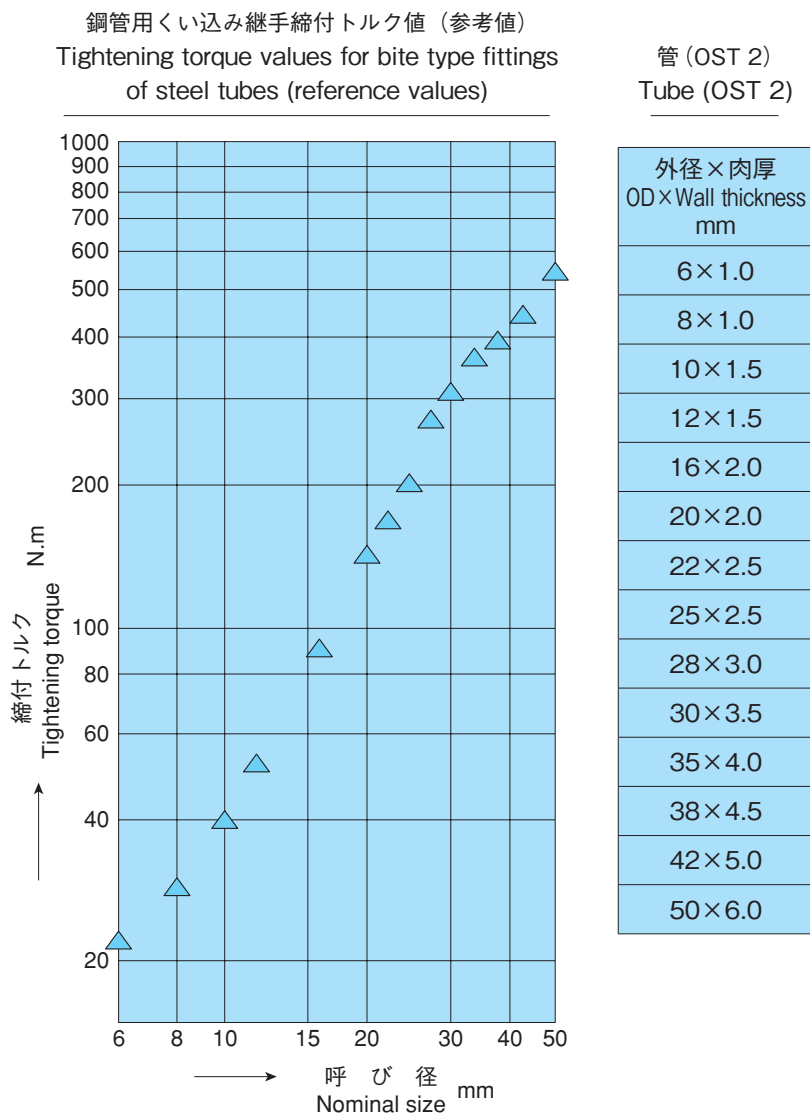

13. くい込み継手用締付装置 (PSD-S) / PRE-SETTING DEVICE MODEL : PSD-S

(1) 締付装置PSD-Sの構造と機能 / Structure and Function of Pre-Setting Device PSD-S

本装置は下図に示すように、カム機能により、管外径φ4～φ20、1/8B～3/8B用のくい込み継手の予備締付けを行うものです。レバーを下方に押しつけることにより、押し棒に取付けられた締付治具は、偏心軸（カム）の作用で締付板側へスライドしスリーブを管に食い込ませます。

This device performs pre-setting by cam mechanism as illustrated in the figure below for bite type fittings within the tube range of 4 to 20 mm outside diameter or 1/8B to 3/8B.

By pressing the lever down, the clamping jig attached to the push rod slides toward the clamping plate by cam action and force the sleeve to bite into the tube.



図-1 締付装置機構図 装置重量 17kg
Figure 1. Pre-setting device mechanism Weight : 17kgs.



図-2 締付部詳細図
Figure 2. Detailed drawing of pre-setting components

(2) 標準部品 (別売) / STANDARD COMPONENTS

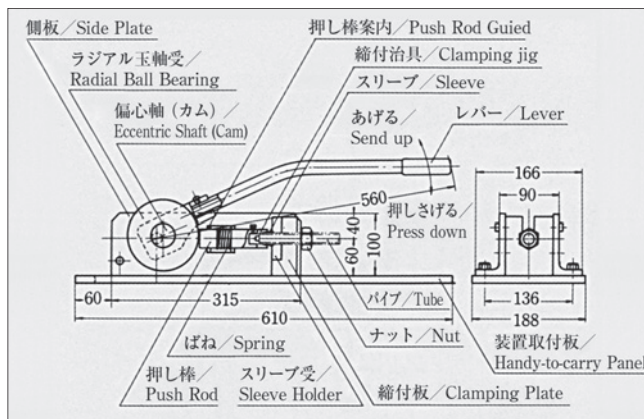
本装置 (PSD-S) による予備締付けには、右表より管外径に適合した締付治具及びスリーブ受を選定の上ご使用ください。

なお、締付装置本体と締付治具・スリーブ受とは別売りとなります。

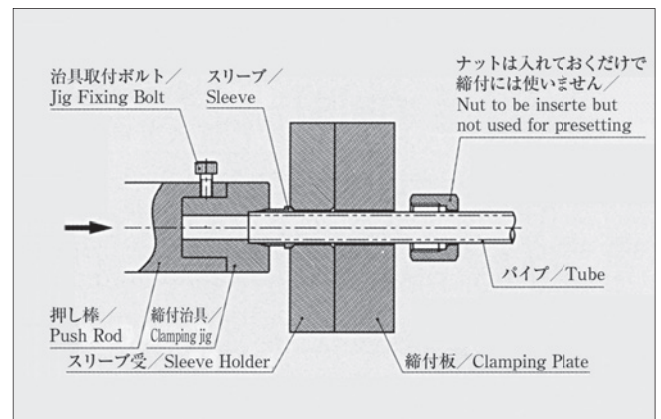
For pre-setting with this device (PSD-S) it will be necessary to select clamping jig and sleeve holder applicable to the outside diameter of the tube to be used.

The clamping jigs and sleeve holders are not included with the pre-setting device and must be separately ordered.

管外径 Tube OD	締付治具 Clamping jig	スリーブ受 Sleeve holder
4	PJS04-000N (PSD-SJ-4)	PJU04-00SN (PSD-SU-4)
6	PJS06-000E (PSD-SJ-6)	PJU06-00SE (PSD-SU-6E)
8	PJS08-000E (PSD-SJ-8)	PJU08-00SE (PSD-SU-8E)
10	PJS10-000E (PSD-SJ-10)	PJU10-00SE (PSD-SU-10E)
12	PJS12-000E (PSD-SJ-12)	PJU12-00SE (PSD-SU-12E)
15	PJS15-000E (PSD-SJ-15)	PJU15-00SE (PSD-SU-15E)
16	PJS16-000E (PSD-SJ-16)	PJU16-00SE (PSD-SU-16E)
18	PJS18-000E (PSD-SJ-18)	PJU18-00SE (PSD-SU-18E)
20	PJS20-000E (PSD-SJ-20)	PJU20-00SE (PSD-SU-20E)
1/8B	PJS11-000N (PSD-SJ-G1/8)	PJU11-00SN (PSD-SU-G1/8)
1/4B	PJS13-000E (PSD-SJ-G1/4)	PJU13-00SN (PSD-SU-G1/4)
3/8B	PJS17-000N (PSD-SJ-G3/8)	PJU17-00SN (PSD-SU-G1/8)

(3) 注意事項 / CAUTION

1) 管は直角に切断し、管端内外面のバリを取ってください。

△注意：管端の切断角度は90°±1°以内を目安に切断してください。又、管表面には深さ0.1mm以上のキズを付けないようにしてください。

2) 曲管の場合、その管端部の直線長さは80mm以上とってください。

3) 本装置の可動部には適宜注油してください。

△注意：装置や治具を改造しないでください。改造が原因で、装置の機能が発揮できなくなる可能性があります。

1) Cut the tube at a right angle and remove all burrs from the outside and inside of the cut tube end.

△CAUTION: Cut the tube aiming at an angle of 90° ±1° outer surface of the tube must be free from the scratched damage of more deeper than 0.1mm.

2) In case of bent tube, the straight portion of the tube must be longer than 80mm from both tube ends.

3) Lubricate the moving parts of the device with oil timely.

△CAUTION: Do not modify the device and jigs. The device may not function properly when modification has been performed.

(4) 締付装置PSD-Sの操作方法 / OPERATION PROCEDURE OF PRE-SETTING DEVICE PSD-S

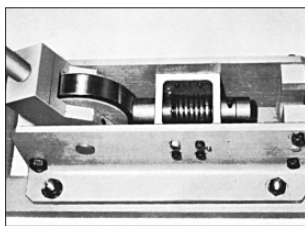

①レバーをあげ、押し棒と締付板との間をあけます。

①Raise the lever and open space between the push rod and the clamping plate.

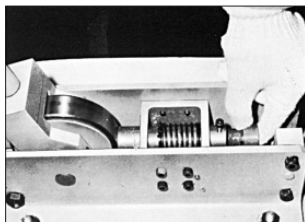

②管と同じサイズの締付治具を取りつけます。

②Attach a clamping jig of the same size as the tube.

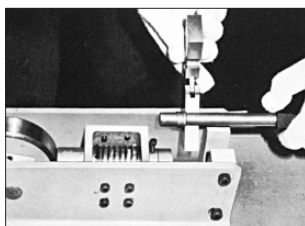

③ナット・スリーブの順序・方向をまちがえないように管へ挿入し、ナットとスリーブの間にスリーブ受をセットします。

③Insert the nut and the sleeve into the tube with correct order and direction, and set the sleeve holder between the nut and the sleeve.

⚠警告：スリーブの方向に注意してください。逆に取付けますと管へのくい込みが得られず管抜け事故の原因となります。

⚠WARNING: Make sure the correct direction of sleeve. If the sleeve is facing the incorrect direction, the sleeve will not bite into the tube and tube slippage failure will result.

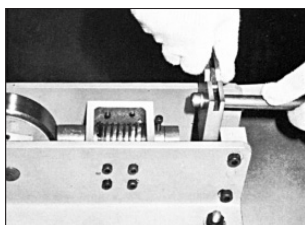

④そのまま締付装置に取りつけます。

④Mount the tube with the nut and the sleeve on the pre-setting device.

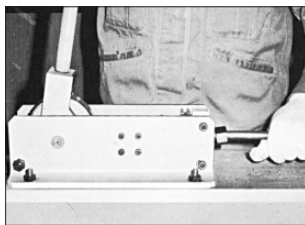

⑤管端を締付治具の管突き当て部に確実に当てます。

⑤The tube end must be contacting and seated firmly against the shoulder of the clamping jig.

⚠警告：管端が、管突き当て部より浮いた状態で締付けますと充分なくい込み状態が得られず管抜け事故の原因となります。

⚠WARNING: When clamping is performed with the tube end not contacting the shoulder of the pre-setting device, biting into the tube will not be satisfactory and cause the tube to slip.

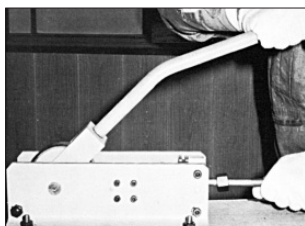

⑥レバーを押し下げます。

⑥Push down on the lever.

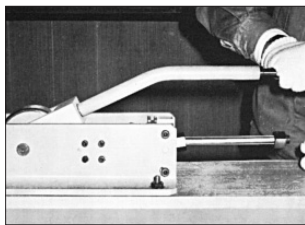

⑦レバーが動かなくなるまで締付けます。

⑦Clamp down on the lever until it can no longer be pressed.

⚠注意：レバーは突当るまで確実に押し下げてください。

⚠CAUTION: Press down on the lever until firmly contacting.

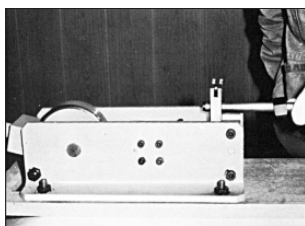

⑧レバーをあげ、締付部分をゆるめ、二つ割りのスリーブ受とともに管を取りはずします。以上で予備締付けは完了です。

⑧Lift up the lever to loose the clamp and remove the tube with the two-piece sleeve holder. The presetting operation completed.

(5) 本締付け / FINAL TIGHTENING

予備締付けの終わった管を実際の配管場所にて継手本体に取付けます。この時、ナットをスパナで締付けて行くと急に手ごたえが増す点があり、(シャープトルクライズポイント) この点からさらに1/4回転締付けると取付けは完了します。

The tube that have been pre-set is now ready to be installed to the fitting body at the piping site.

In the installing operation, the tightening torque while tightening the nut with a spanner will suddenly increase upon reaching a certain point called (sharp torque rise point), then from this point turn additionally 1/4 turn to complete the installation.

- ⚠ 警告：ナット締付けの際は足場を確保し、周囲の安全を確認してください。
- ⚠ 注意：締め不足は漏れや管抜けの原因となります。
又、過剰な締付けは継手を損傷し、機能を損なう恐れがあります。
- ⚠ 注意：プリセット後のスリーブ及び継手本体のテーパ穴面は組付前にウェス、エアー等で清掃してください。
異物の噛み込みはシール機能を損なう恐れがあります。

⚠ WARNING: Perform tightening of the nut on firm footing, and ascertain the safety of the surrounding.

⚠ CAUTION: Insufficient tightening can result in leakage and tube slippage.

⚠ CAUTION: Clean the sleeve after pre-setting and the taper bore of the fitting body with cloth and blow clean with compressed air before assembling. When foreign material becomes caught, sealing function can be impaired.

14. くい込み継手用締付装置 (PSD-B) / PRE-SETTING DEVICE Model : PSD-B

(1) 締付装置PSD-Bの構造と機能 / Structure and Function of Pre-Setting Device PSD-B

本装置は下図に示すように、トグル機構の応用により、管外径 $\phi 22 \sim \phi 50$ 、1/2B \sim 1-1/2B用のくい込み継手の予備締付けを行うものです。($\phi 6 \sim \phi 20$ 用も、ご要望により製作いたします。)

ハンドルを右回転させることにより、移動フランジに取りつけられた締付治具は、トグル機構により固定フランジA側へスライドし、スリーブを管に食い込ませます。

This device performs pre-setting of bite type fittings within the tube range of 22 to 50mm outside diameter or 1/2B to 1-1/2B by toggle mechanism application as illustrated in the figure below. Upon request, the device for 6mm to 20mm diameter will be available.

By turning the handle in the right direction, the clamping jig attached to the moving flange slides toward the fixed flange A by the toggle mechanism and forces the sleeve to bite into the tube.



図-1 締付装置機構図 装置重量：33kg
Figure 1. Diagram of pre-setting device. Weight :33kgs.



図-2 締付部詳細図
Figure 2. Details of clamping mechanism

(2) 標準部品 (別売) / Standard Components (sold separately)

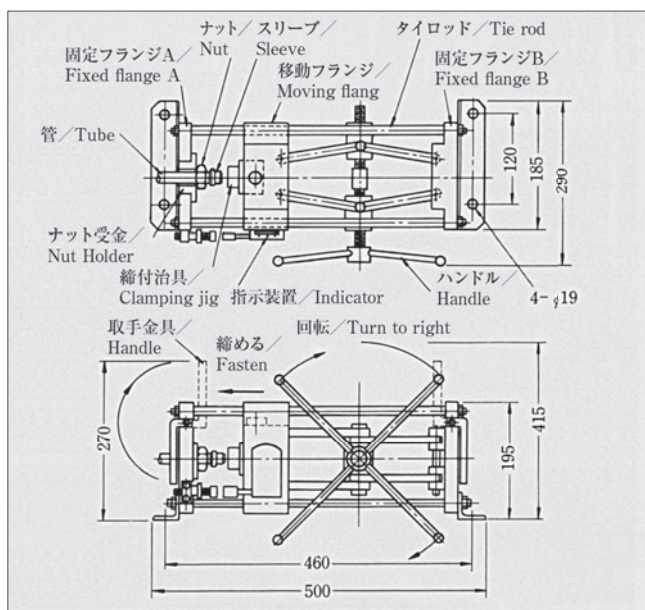
本装置 (PSD-B) による予備締付けには、管外径に適合した締付治具およびナット受金を下表より選定の上ご使用ください。なお、締付装置本体と締付治具・ナット受金とは別売りとなります。

For pre-setting with this device(PSD-B), it will be necessary to select clamping jig and nut holder that are applicable to the outside diameter of the tube to be used from the Table below.

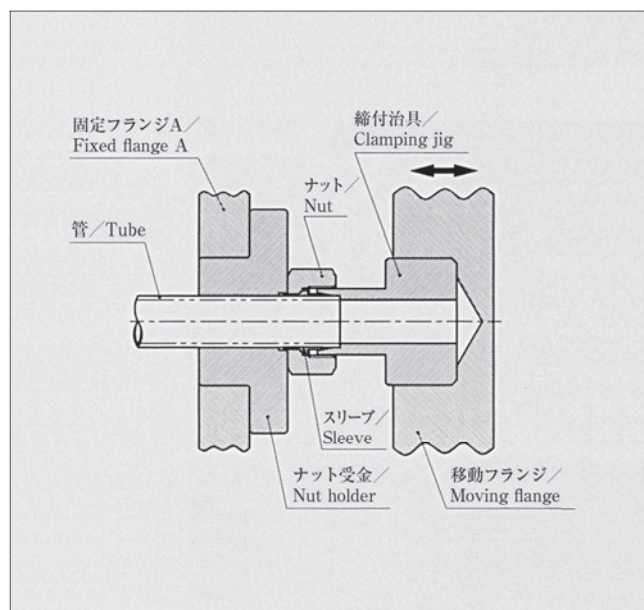
The clamping jig and nut holder are not included in the pre-setting device and must be separately purchased.

管外径 Outside of Tube	締付治具 Clamping Jig	ナット受金 Nut Holder	管外径 Outside of Tube	締付治具 Clamping Jig	ナット受金 Nut Holder
22	PJB22-000E (PSD-BJ-22E)	PJU22-00BE (PSD-BU-22E)	42	PJB42-000N (PSD-BJ-42N)	PJU42-00BN (PSD-BU-42)
25	PJB25-000E (PSD-BJ-25E)	PJU25-00BE (PSD-BU-25E)	50	PJB50-000N (PSD-BJ-50N)	不要 Useless
28	PJB28-000E (PSD-BJ-28E)	PJU28-00BE (PSD-BU-28E)	1/2B	PJB22-000E (PSD-BJ-21N)	PJU22-00BE (PSD-BU-22)
30	PJB30-000E (PSD-BJ-30E)	PJU30-00BE (PSD-BU-30E)	3/4B	PJB27-000N (PSD-BJ-27N)	PJU28-00BE (PSD-BU-28)
35	PJB35-000E (PSD-BJ-35E)	PJU35-00BE (PSD-BU-35E)	1B	PJB34-000N (PSD-BJ-34N)	PJU35-00BE (PSD-BU-35)
38	PJB38-000N (PSD-BJ-38N)	PJU38-00BE (PSD-BU-38)	11/4B	PJB43-000N (PSD-BJ-43N)	PJU42-00BN (PSD-BU-42)
40	PJB40-000N (PSD-BJ-40N)	PJU40-00BN (PSD-BU-40)	11/2	PJB48-000N (PSD-BJ-48N)	不要 Useless

(3) 注意事項 / CAUTION

1) 管は直角に切断し、管端内外バリを取ってください。

⚠ 注意：管端の切断角度は $90^\circ \pm 1^\circ$ を目安に切断してください。

又、管表面には深さ0.1mm以上のキズを付けないようにしてください。

2) 曲管の場合、その管端部の直線長さは80mm以上とってください。

3) 本装置の可動部には適宜注油してください。

⚠ 注意：装置や治具を改造しないでください。

改造が原因で装置の機能が発揮できなくなる可能性があります。

1) Cut the tube at a right angle to the center line, and remove all burrs from the outside and inside of the cut tube end.

⚠ CAUTION: Aim at obtaining $90^\circ \pm 1^\circ$ at the cutting angle of the tube end. Handle with care to prevent scratching deeper than 0.1 mm on the tube surface.

2) In case of bent tube, the straight portion of the tube must be longer than 80mm from the tube end.

3) Lubricate the moving parts of the device with oil.

⚠ CAUTION: Do not perform modification on the device and jig. The device may not function properly when modified.

(4) 締付装置PSD-Bの操作方法 / OPERATION PROCEDURE OF PRE-SETTING DEVICE PSD-S

1) ハンドルを左回転（反時計回り）させ、移動フランジと固定フランジAとの間をあけます。そして管径に適応したナット受金を固定フランジAに、締付治具を移動フランジにそれぞれ取り付けます。

1) Turn the handle to the left(counter clockwise) and open space between the moving flange and stationary flange A. Attach a nut holder which is corresponding to the tube diameter to the stationary flange A and a clamping jig to the moving flange.

⚠警告：装置は安定した作業台に乗せ、作業中転倒、落下のないよう作業台に固定してください。

⚠注意：ナット受金及び締付治具は固定ボルトで固定してください。

⚠WARNING: Place the device on a stable work bench and firmly fix the device to the work bench so that the device will not turn over or fall during use.

⚠CAUTION: Firmly fix the nut holder and clamping jig with securing bolts.



写真-1 / Photo 1



写真-2 / Photo 2

2) ナット・スリーブの順序・方向をまちがえないように管へ挿入し、写真-1に示すように、ナット受金と締付治具との間にセットします。

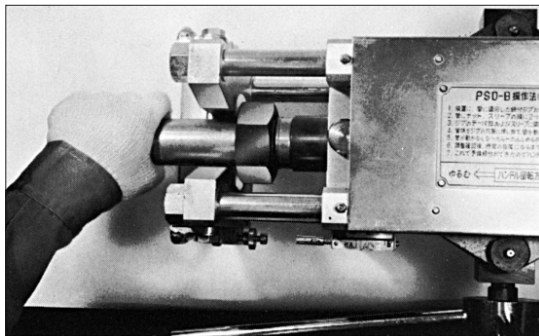
このとき治具のテーパ部およびスリーブに潤滑油を塗ってください。

2) Insert the nut and the sleeve into the tube, with correct sequence and direction and set between the nut holder and the clamping jig as shown in Photo 1.

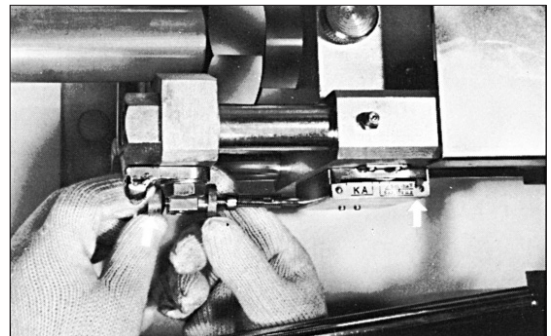
Lubricate the tapered part of the jig and the sleeve with lubricant.

⚠警告：ナット、スリーブの方向を間違えますと、継手を損傷したり管抜け事故の原因となります。

⚠WARNING: If the nut or the sleeve is inserted into the tube facing the wrong direction, it may cause the damage of fitting and slipping-off the tube.

3) 管端を締付治具の管突き当て部に押し当て、管を円周方向にわずかに動かしながらハンドルを締めます(右回転)。管が動かなくなったら一時ハンドルの締付けを止め、指示装置の指針を目盛の0に合わせ、調整ねじを固定します。(写真-2)

3) Insert the tube into the pre-setting device so that the tube end contacts the shoulder of the pre-setting device. Clamp with the handle while slightly moving the tube circumferentially (turning to the right).

When the tube no longer moves, temporarily stop clamping with the handle and set the pointer on the indicator to "0 (Zero)" scale.

Fix the adjustment screw.

⚠警告：管端が管突当て部より浮いた状態で締付けますと充分なくい込み状態が得られず管抜け事故の原因となります。

⚠WARNING: When clamping is performed with the tube end not contacting the shoulder in the pre-setting device, biting effect into the tube will be insufficient and cause the tube to slip.



写真-3/Photo 3



写真-4/Photo 4

4) 指針調整後、指針が所定の目盛に合うまでハンドルを締めます。(写真-3では指針は目盛板のほぼ中央にきています。)

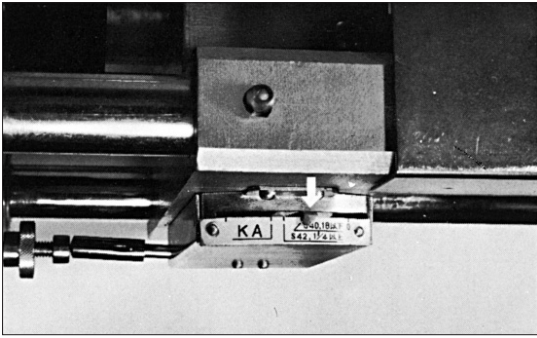
4) After adjusting the indicator, clamp by turning the handle until the pointer points to the required point on the scale. (In photo 3, the pointer is pointing to the center on the scale.)

5) ハンドルをゆるめ（左回転）管を取りはずします。(写真-4)
以上で予備締付けは完了です。

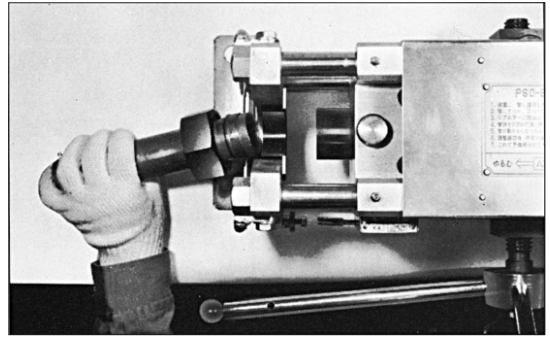
5) Loosen by turning the handle (to the left) and remove the tube.
This completes the pre-setting procedure.

⚠ 警告：締め不足は漏れや管抜けの原因となります。又、過剰な締付けは、継手を損傷し機能を損なう恐れがあります。

⚠ WARNING: Inadequate clamping can result in leakage and tube slippage. However, excessive clamping can cause damage of fitting.

注：なお、装置の上面カバーに操作法銘板が付けてありますのでご参照ください。

Note: An operation procedure plate is attached on the top cover of the device and can be used as reference.

(5) 本締付け/FINAL TIGHTENING

予備締付けの終わった管を実際の配管場所にて継手本体に取付けます。この時ナットをスパナで締付けて行くと急に手ごたえが増す点があり、(シャープトルクライズポイント) この点からさらに1/4回転締付けると取付けは完了します。

The tube that have been pre-set is now ready to be installed to the fitting body at the piping site.

In the installing operation, the tightening torque while tightening the nut with a spanner will suddenly increase upon reaching a certain point(sharp torque rise point), and from this point an additional 1/4 turn will complete the final tightening.

⚠ 警告：ナット締付けの際は足場を確保し、周囲の安全を確認してください。

⚠ 注意：締め不足は漏れや管抜けの原因となります。

又、過剰な締付けは継手を損傷し機能を損なう恐れがあります。

⚠ 注意：プリセット後のスリーブ及び継手本体のテーパ穴面は、組付け前にウェス、エア等で清掃してください。異物の噛み込みはシール機能を損なう恐れがあります。

⚠ WARNING: Perform tightening of the nut on firm footing, and ascertain the safety of the surrounding.

⚠ CAUTION: Insufficient tightening can result in leakage and tube slippage.

⚠ CAUTION: Clean the sleeve after pre-setting and the taper bore of the fitting body with cloth and blow clean with compressed air before assembling. When foreign matter becomes caught, sealing function can be impaired.

15. 油圧式締付装置 PSD-H / Hydraulic Pre-Setting Device MODEL : PSD-H

PSD-HT(適用管サイズ/Tube size: $\phi 6 \sim \phi 30$ 8A~20A) PSD-HB(適用管サイズ/Tube size: $\phi 15 \sim \phi 50$ 10A~40A)

鋼管用くい込み継手の予備締付けができ、オプションのフットスイッチを取り付けることにより手動式ではサポートを必要とするような3次元曲げ加工した長い管でもフットスイッチにより一人作業が可能です。

The hydraulic pre-setting device enables pre-setting for steel tube bite type fittings, and long tube with three dimensional bending which required support with manual type pre-setting device can be performed by one operator with the foot switch.

油圧式締付装置 PSD-HT 操作方法 / Operation procedure of Hydraulic Pre-Setting Device PSD-HT

1. 電源を入れ、油圧ポンプスイッチをONにします。
2. リリーフ弁調整ハンドルをまわし使用する管の外径、肉厚により指定されたプリセット圧力をフットスイッチを操作しながら設定をします。
3. 管にナット、スリーブを装着しシリンダー前部の締付治具に挿入します。
4. フットスイッチをONにします。シリンダーが前進し予備締付けを行います。
5. 予備締付けかできたら、シリンダーは自動的に戻ります。
6. 操作中に異常が発生した場合は非常停止ボタンを押してください。

1. Turn on the power and start the hydraulic pump.
2. By turning the relief valve adjustment handle. Set the pre-set pressure as specified per the outer diameter and wall thickness of the tube operating the foot switch.
3. Install the nut and sleeve into the tube and insert the clamping jig to the front of the cylinder.
4. Turn on the foot switch. The cylinder will advance and perform pre-setting.
5. When pre-setting has been completed, the cylinder will automatically return.
6. In case of emergency during operation, push the emergency stop button.

装置寸法及び各部名称 / Details of the clamping mechanism

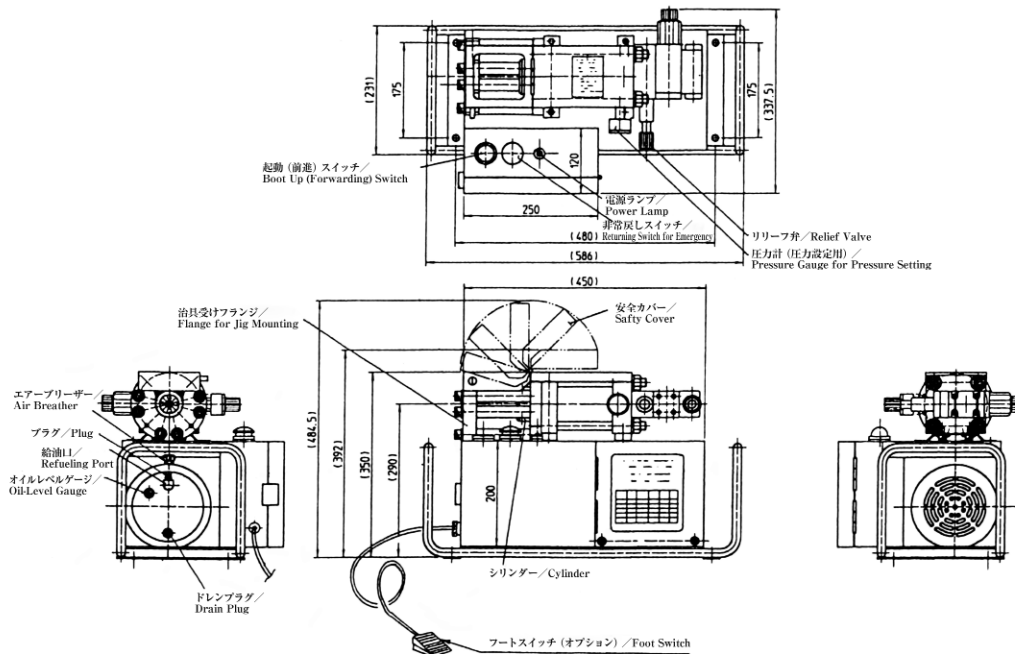





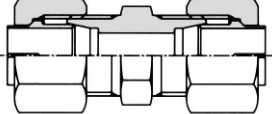
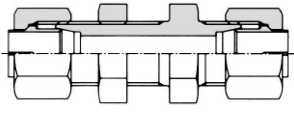
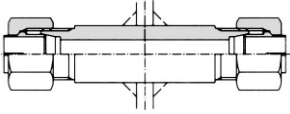

⚠ 警告：御利用の際は、取扱説明書をお読み頂き正しく取扱いをしてください。

⚠ WARNING: Before use, read the operation manual and operate correctly.

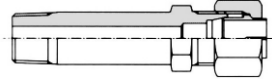
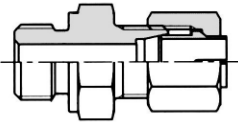
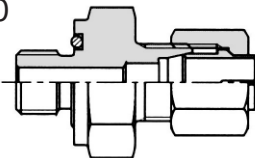
寸法表 / Dimension Sheet

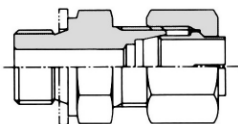
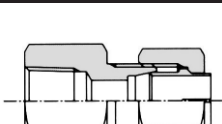
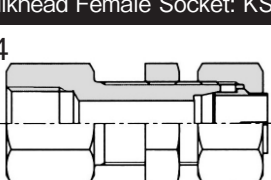
NE形鋼管用くい込み継手 / NE BITE TYPE TUBE FITTINGS 製品インデックス / VISUAL INDEX

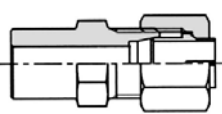
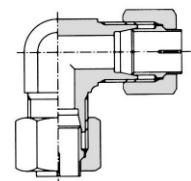
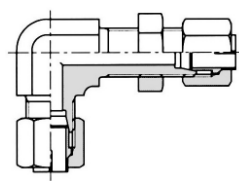
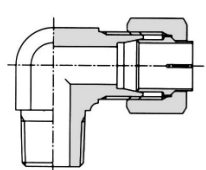
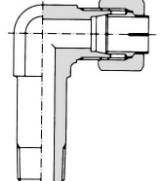
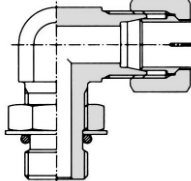
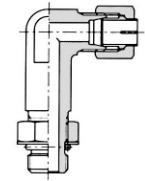
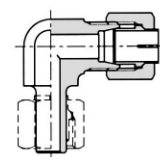
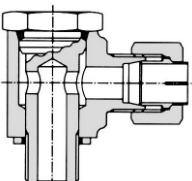
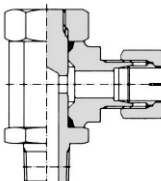
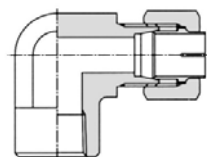
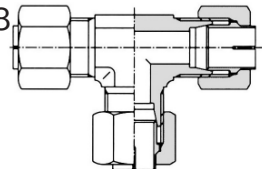
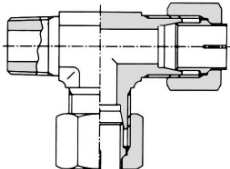
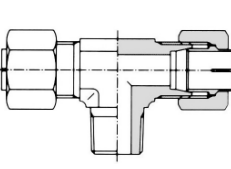
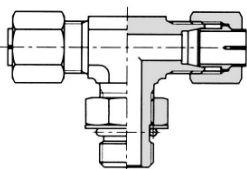
ユニオン : KUA Union: KUA	隔壁締付ユニオン : KSU Bulkhead Union: KSU	隔壁溶接ユニオン : KUW Bulkhead Weld Union: KUW	コネクタ (おす) : KCT Male Connector: KCT
4 	5 	6 	7 
ロングコネクタ : KCC Extended Male Connector: KCC	平行ねじコネクタ (Oリング、ボンデッドシール用) : KCO Straight Thread Connector: KCO	平行ねじコネクタ (Oリングシール用) : KCD O-ring Seal Straight Thread Connector: KCD	平行ねじロングコネクタ (Oリング、ボンデッドシール用) : KCG Straight Thread Extended Male Connector: KCG
8 	9 	10 	11 
平行ねじコネクタ (銅ガスケット用) : KCJ Straight Thread Connector: KCJ	コネクタ (めす) : KSA Female Connector: KSA	隔壁締付ソケット : KSS Bulkhead Female Socket: KSS	圧力計用コネクタ : KGA Connector for Pressure Gauge: KGA
12 	13 	14 	15 
圧力計用コネクタ (Oリングシール用) : KGO Connector for Pressure Gauge (O-Ring Seal): KGO	溶接形コネクタ : KCW Weld Male Connector: KCW	エルボ : KLA Union Elbow: KLA	隔壁締付エルボ : KSL Bulkhead Union Elbow: KSL
16 	17 	18 	19 
エルボニップル : KLN Male Elbow: KLN	ロングエルボ : KLL Extended Male Elbow: KLL	Oリングガスケット形エルボニップル : KLO O-Seal Male Elbow: KLO	Oリングガスケット形ロングエルボニップル : KLG O-Seal Extended Male Elbow: KLG
20 	21 	22 	23 
方向調整エルボ : KLC Adjustable Elbow: KLC	スタッドエルボ (B形) : KMB Stud Elbow (B type): KMB	スタッドエルボ (C形) : KMC Stud Elbow (C type): KMC	エルボ (めす) : KLF Female Elbow: KLF
24 	25 	26 	27 
ティー : KTA Union Tee: KTA	ティー片ニップル : KTK Male Run Tee: KTK	ティー中ニップル : KTN Male Branch Tee: KTN	Oリングガスケット形ティー : KTO O-Seal Male Branch Tee: KTO
28 	29 	30 	31 

NE形鋼管用くい込み継手 / NE BITE TYPE TUBE FITTINGS 製品インデックス / VISUAL INDEX

ティー片ニップル (めす) : KTF Female Run Tee: KTF	ティー中ニップル (めす) : KTH Female Branch Tee: KTH	方向調整片ティー : KTC Adjustable Run Tee: KTC	方向調整中ティー : KTB Adjustable Branch Tee: KTB
32	33	34	34
クロス : KXA Union Cross: KXA	キャップ : KCA Cap: KCA	プラグ : KBA Plug: KBA	レジューサー : KRE Reducer: KRE
35	35	36	37
アダプタ : KHA Adapter: KHA	平行ねじアダプタ (Oリング, ボンデットシール用) : KHB Straight Thread Adapter: KHB	平行ねじアダプタ (Oリングシール用) : KH0 O-Ring Seal Straight Thread Adapter: KH0	平行ねじアダプタ (銅ガスケット用) : KHC Straight ThreadAdapter (For Copper Gasket): KHC
38	39	40	41
エア抜きバルブ : KAP Air-Purge Valve: KAP	ねじ込み形エア抜きバルブ : SAP Air-Purge Valve: SAP	ホース接続ユニオン : KUC Male Seat Hose Connection Union: KUC	ホース接続ユニオン (めす) : KUD Female Seat Hose Connection Union: KUD
42	42	43	44
ホース接続隔壁ユニオン : KUE Male Seat Hose Connection Bulkhead Union: KUE	ホース接続隔壁ユニオン (めす) : KUF Female Seat Hose Connection Bulkhead Union: KUF	ホース接続ユニオンエルボ : KLD Male Seat Hose Connection Union Elbow: KLD	ホース接続ユニオンエルボ (めす) : KLE Female Seat Hose Connection Union Elbow: KLE
45	46	47	48
ホース接続隔壁ユニオンエルボ : KLH Male Seat Hose Connection Bulkhead Elbow: KLH	ホース接続隔壁ユニオンエルボ (めす) : KLS Female Seat Hose Connection Bulkhead Elbow: KLS	ホース接続ティー片ニップル (めす) : KTG Female Seat Hose Connection Run Tee: KTG	ホース接続ティー片ニップル : KTJ Male Seat Hose Connection Run Tee: KTJ
49	50	51	52
ホース接続ティー中ニップル (めす) : KTE Female Seat Hose Connection Branch Tee: KTE	ホース接続ティー中ニップル (おす) : KTD Male Seat Hose Connection Branch Tee: KTD	ホース接続エルボ (めす) : HLE Female Seat Hose Connection Elbow: HLE	ホース接続エルボ (おす) : HLD Male Seat Hose Connection Elbow: HLD
53	54	55	56

NE形鋼管用くい込み継手／NE BITE TYPE TUBE FITTINGS 製品インデックス／VISUAL INDEX

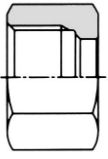
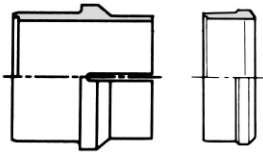
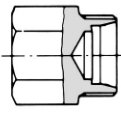
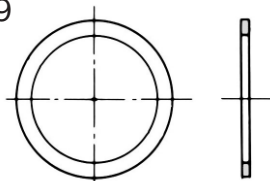
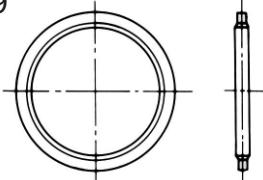
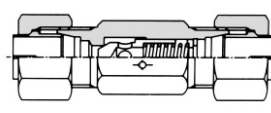
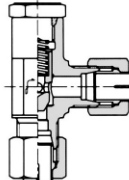
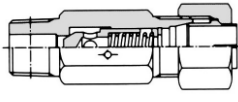
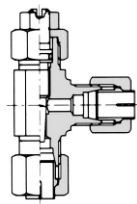
ナット：KKN Nut: KKN	スリーブ：KKO Sleeve: KKO	締付治具：PJA Hand Presetting Tool: PJA	銅ガスケット：KP-A Copper Gasket: KP-A
57 	57 	58 	59 
ボンデッドシール：KP-C Bonded Seal: KP-C	チェックユニオン：KZU Check Union: KZU	チェックエルボ：KZL Check Elbow: KZL	チェックコネクタ：KZC Check Connector: KZC
59 	62 	63 	64 
可変式絞り継手：KTP Orifice Adjustable Fitting: KTP			
65 			

本カタログでの注意表示意味

- ⚠ 警告：この表示を無視して誤った取扱いをすると、人身障害や死亡事故が発生する恐れがあることを示します。
- ⚠ 注意：この表示を無視して誤った取扱いをすると、くい込み継手の機能が発揮できない可能性があることを示します。

Directions meaning shown in this catalogue

- ⚠ WARNING: Irregular handling with disregard for this direction can induce physical disability and accidental death.
- ⚠ CAUTION: Irregular handling with disregard for this direction can induce functional defect of bite type fitting.

ユニオン

UNION

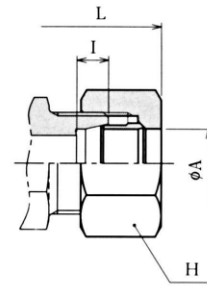
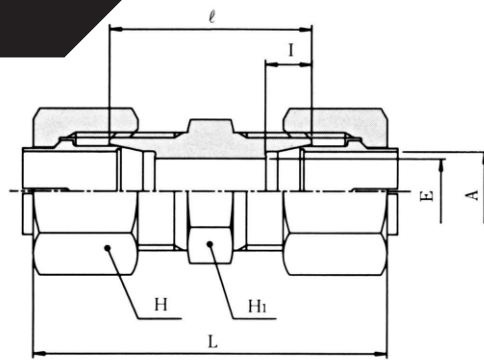

※印サイズの形状
※NS Type

単位：mm/Unit: mm

継手の呼び Part No.	適用管外径 Out. Dia. of Applied Pipe A		E	六角対辺 Hex Width		I	ℓ	手締め(約) Fingertight Length (about) L	重量 Weight (kg)
	呼び径 Nominal sizes	外径 Out. Dia.		H ₁	H				
※KUA04-000N		4	2.5	12	12	6	20	35	0.022
KUA06-000E		6	4	14	14	7	30	51	0.042
KUA08-000E		8	6	17	17	7	31	52	0.059
KUA10-000E		10	8	17	19	7	31	54	0.068
KUA12-000E		12	10	19	22	7	31	54	0.093
KUA15-000E		15	12	24	27	7.5	36	61	0.165
KUA16-000E		16	13	27	30	7.5	36	61	0.216
KUA18-000E		18	14	27	32	8	36	61	0.227
KUA20-000E		20	17	30	36	8	38	63	0.305
KUA22-000E		22	18	32	36	9	38	63	0.279
KUA25-000E		25	20	36	41	10	39	66	0.395
KUA28-000E		28	22	41	46	10	43	71	0.535
KUA30-000E		30	25	41	46	10	43	72	0.512
KUA35-000E		35	28	46	55	11	44	79	0.788
※KUA38-000N		38	32	50	60	12	46	85	1.013
※KUA40-000N		40	32	55	60	12	55	94	1.137
※KUA42-000N		42	34	55	60	12	55	94	1.071
※KUA50-000N		50	40	65	75	12	60	103	1.909
※KUA11-000N	1/8	10.5	8	17	19	7	31	54	0.072
※KUA13-000N	1/4	13.8	11	22	24	7.5	36	60	0.130
※KUA17-000N	3/8	17.3	14	27	32	8	36	61	0.230
※KUA21-000N	1/2	21.7	18	32	36	9	38	63	0.287
※KUA27-000N	3/4	27.2	22	41	46	10	43	71	0.542
※KUA34-000N	1	34.0	28	46	55	11	44	79	0.801
※KUA43-000N	1 1/4	42.7	34	60	65	12	57	96	1.432
※KUA48-000N	1 1/2	48.6	40	65	75	12	60	103	1.942

注. 予告なしに、品質・性能・改善のため寸法を変更する事があります。

Note. Dimensions might be modified due to improvement of quality and performance.

隔壁締付ユニオン

BULKHEAD UNION

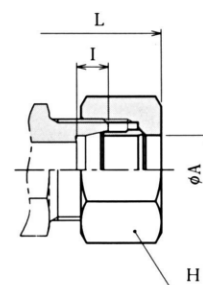
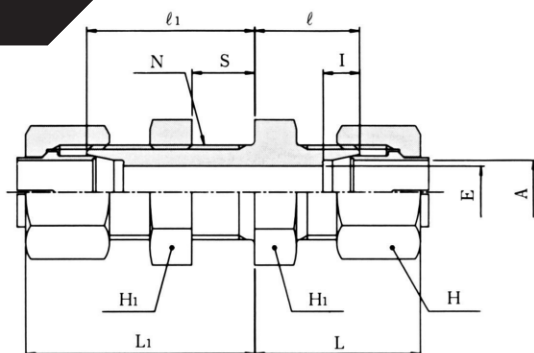

※印サイズの形状
※NS Type

単位：mm / Unit: mm

継手の呼び Part No.	適用管外径 Out. Dia. of Applied Pipe A		E	六角対辺 Hex Width		I	l ₁	l	手締め(約) Fingertight Length (about)		N	最大 Max S	重量 Weight (kg)
	呼び径 Nominal sizes	外径 Out. Dia.		H ₁	H				L ₁	L			
※KSU04-000N		4	2.5	14	12	6	25	14	32.5	21.5	M10×1.25	13	0.041
KSU06-000E		6	4	17	14	7	32	19	42.5	29.5	M12×1.5	13	0.070
KSU08-000E		8	6	19	17	7	32	19	42.5	29.5	M14×1.5	13	0.092
KSU10-000E		10	8	22	19	7	32	20	43.5	31.5	M16×1.5	13	0.122
KSU12-000E		12	10	24	22	7	32	20	43.5	31.5	M18×1.5	13	0.148
KSU15-000E		15	12	27	27	7.5	37	22	49.5	34.5	M22×1.5	15	0.232
KSU16-000E		16	13	30	30	7.5	37	24	49.5	36.5	M24×1.5	15	0.314
KSU18-000E		18	14	32	32	8	39	24	51.5	36.5	M26×1.5	15	0.252
KSU20-000E		20	17	36	36	8	39	24	51.5	36.5	M28×1.5	15	0.405
KSU22-000E		22	18	36	36	9	39	25	51.5	37.5	M30×1.5	15	0.425
KSU25-000E		25	20	41	41	10	39	25	52.5	38.5	M35×1.5	15	0.588
KSU28-000E		28	22	46	46	10	41	28	55	42	M38×1.5	15	0.785
KSU30-000E		30	25	46	46	10	41	28	55.5	42.5	M40×1.5	15	0.722
KSU35-000E		35	28	50	55	11	43	30	60.5	47.5	M45×1.5	15	1.068
※KSU38-000N		38	32	55	60	12	45	31	64.5	50.5	M48×1.5	15	1.384
※KSU40-000N		40	32	60	60	12	50	37	69.5	56.5	M52×2	15	1.646
※KSU50-000N		50	40	70	75	12	50	43	71.5	64.5	M64×2	15	2.639
※KSU11-000N	1/8	10.5	8	22	19	7	32	20	43.5	31.5	M16×1.5	13	0.120
※KSU13-000N	1/4	13.8	11	27	24	7.5	37	22	49	34	M20×1.5	15	0.188
※KSU17-000N	3/8	17.3	14	32	32	8	39	24	51.5	36.5	M26×1.5	15	0.345
※KSU21-000N	1/2	21.7	18	36	36	9	39	25	51.5	37.5	M30×1.5	15	0.433
※KSU27-000N	3/4	27.2	22	46	46	10	41	28	55	42	M38×1.5	15	0.764
※KSU34-000N	1	34.0	28	50	55	11	43	30	60.0	47.5	M45×1.5	15	1.106
※KSU43-000N	1 1/4	42.7	34	65	65	12	50	40	69.5	59.5	M56×2	15	2.058
※KSU48-000N	1 1/2	48.6	40	70	75	12	50	43	71.5	64.5	M64×2	15	2.672

△注意：この形式の継手は障壁貫通を目的としたもので、強振動の発生する個所、或いは接続ホースの圧力変動が大きい個所では配管クランプ等、振動対策（継手に掛かる発生応力を軽減するため）が必要です。

注. 予告なしに、品質・性能・改善のため寸法を変更する事があります。

△CAUTION: This type of fitting is designed to be used for wall penetration. When used in the place of strong vibration and / or pressure fluctuation, proper vibration measures such as fixing the piping by clamp are required.

Note. Dimensions might be modified due to improvement of quality and performance.

隔壁溶接ユニオン

BULKHEAD WELD UNION

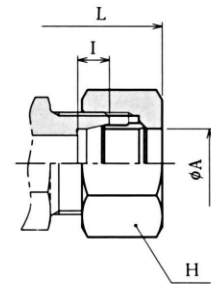
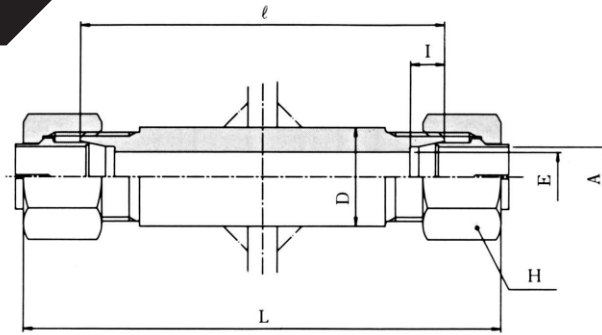

※印サイズの形状
※NS Type

単位：mm/Unit: mm

継手の呼び Part No.	適用管外径 Out. Dia. of Applied Pipe A		E	D	六角対辺 Hex Width H	I	ℓ	手締め(約) Fingertight Length (about) L	重量 Weight (kg)
	呼び径 Nominal sizes	外径 Out. Dia.							
KUW06-000E	6		4	16	14	7	74	95	0.110
KUW08-000E	8		6	16	17	7	74	95	0.119
KUW10-000E	10		8	19	19	7	74	97	0.156
KUW12-000E	12		10	20	22	7	74	97	0.174
KUW15-000E	15		12	26	27	7.5	78	103	0.205
KUW16-000E	16		13	28	30	7.5	78	103	0.374
KUW18-000E	18		14	28	32	8	78	103	0.379
KUW20-000E	20		17	32	36	8	78	103	0.500
KUW22-000E	22		18	32	36	9	78	103	0.447
KUW25-000E	25		20	38	41	10	78	105	0.648
KUW28-000E	28		22	39	46	10	82	110	0.762
KUW30-000E	30		25	46	46	10	82	111	0.878
KUW35-000E	35		28	46	55	11	82	117	1.056
※KUW38-000N	38		32	55	60	12	82	121	1.472
※KUW40-000N	40		32	55	60	12	90	129	1.539
※KUW50-000N	50		40	65	75	12	90	133	2.342
※KUW11-000N	1/8	10.5	8	19	19	7	74	97	0.153
※KUW13-000N	1/4	13.8	11	22	24	7.5	78	102	0.222
※KUW17-000N	3/8	17.3	14	28	32	8	78	103	0.381
※KUW21-000N	1/2	21.7	18	32	36	9	78	103	0.455
※KUW27-000N	3/4	27.2	22	39	46	10	82	110	0.769
※KUW34-000N	1	34.0	28	46	55	11	82	117	1.094
※KUW43-000N	1 1/4	42.7	34	58	65	12	90	129	1.813
※KUW48-000N	1 1/2	48.6	40	65	75	12	90	133	2.375

注. 予告なしに、品質・性能・改善のため寸法を変更する事があります。

Note. Dimensions might be modified due to improvement of quality and performance.

コネクタ (おす)

MALE CONNECTOR

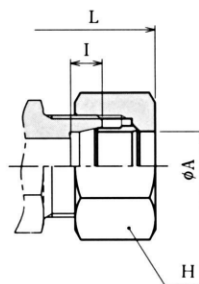
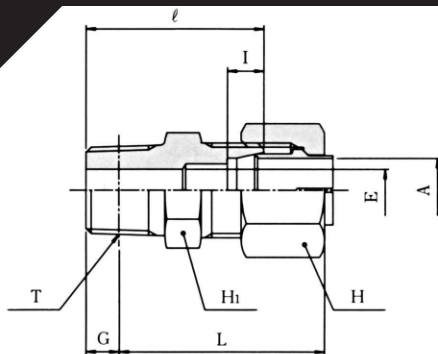

※印サイズの形状
※NS Type

単位：mm / Unit: mm

継手の呼び Part No.	適用管外径 Out. Dia. of Applied Pipe A		(R) T	E	基準径の位置 Engagement Fingertight G	六角対辺 Hex Width		I	ℓ	手締め(約) Fingertight Length (about) L	重量 Weight (kg)
	呼び径 Nominal sizes	外径 Out. Dia.				H ₁	H				
※KCT04-010N	4		1/8	2.5	3.97	12	12	6	22	25.5	0.018
KCT06-010E	6		1/8	4	3.97	14	14	7	28	34.5	0.029
KCT06-020E	6		1/4	4	6.01	17	14	7	33	37.5	0.038
KCT06-030E	6		3/8	4	6.35	19	14	7	34	38	0.056
KCT08-010E	8		1/8	4	3.97	17	17	7	29	35.5	0.043
KCT08-020E	8		1/4	6	6.01	17	17	7	33	37.5	0.046
KCT08-030E	8		3/8	6	6.35	19	17	7	34	38	0.064
KCT10-020E	10		1/4	7	6.01	17	19	7	33	38.5	0.051
KCT10-030E	10		3/8	8	6.35	19	19	7	34	39	0.059
KCT10-040E	10		1/2	8	8.16	22	19	7	39	42.5	0.095
KCT12-020E	12		1/4	7	6.01	19	22	7	33	38.5	0.068
KCT12-030E	12		3/8	9	6.35	19	22	7	34	39	0.071
KCT12-040E	12		1/2	10	8.16	24	22	7	39	42.5	0.103
KCT15-030E	15		3/8	9	6.35	24	27	7.5	37	43	0.114
KCT15-040E	15		1/2	12	8.16	24	27	7.5	41	45.5	0.120
KCT16-030E	16		3/8	9	6.35	27	30	7.5	37	43	0.144
KCT16-040E	16		1/2	12	8.16	27	30	7.5	41	45.5	0.148
KCT18-030E	18		3/8	9	6.35	27	32	8	37	43	0.151
KCT18-040E	18		1/2	12	8.16	27	32	8	41	45.5	0.162
KCT20-040E	20		1/2	12	8.16	30	36	8	43	47.5	0.212
KCT20-060E	20		3/4	16	9.53	30	36	8	45	48	0.228
KCT22-040E	22		1/2	12	8.16	32	36	9	43	47.5	0.203
KCT22-060E	22		3/4	16	9.53	32	36	9	45	48	0.220
KCT25-060E	25		3/4	16	9.53	36	41	10	46	50	0.292
KCT25-080E	25		1	20	10.39	36	41	10	49	52	0.327
KCT28-060E	28		3/4	16	9.53	41	46	10	48	52.5	0.381
KCT28-080E	28		1	22	10.39	41	46	10	51	54.5	0.396
KCT30-080E	30		1	22	10.39	41	46	10	51	55	0.389
KCT30-100E	30		1 1/4	25	12.70	46	46	10	55	57	0.513
KCT35-100E	35		1 1/4	28	12.70	46	55	11	55	60	0.684
※KCT38-120N	38		1 1/2	32	12.70	50	60	12	57	64	0.769
※KCT40-120N	40		1 1/2	32	12.70	55	60	12	62	69	0.867
※KCT42-120N	42		1 1/2	34	12.70	55	60	12	62	69	0.805
※KCT50-160N	50		2	40	15.88	65	75	12	71	76.5	1.489
※KCT11-010N	1/8	10.5	1/8	4	3.97	17	19	7	29	36.5	0.048
※KCT11-020N	1/8	10.5	1/4	7	6.01	17	19	7	33	38.5	0.052
※KCT13-020N	1/4	13.8	1/4	7	6.01	22	24	7.5	36	42	0.088
※KCT13-030N	1/4	13.8	3/8	9	6.35	22	24	7.5	37	42.5	0.093
※KCT17-030N	3/8	17.3	3/8	9	6.35	27	32	8	37	43	0.150
※KCT17-040N	3/8	17.3	1/2	12	8.16	27	32	8	41	45.5	0.163
※KCT21-040N	1/2	21.7	1/2	12	8.16	32	36	9	43	47.5	0.207
※KCT21-060N	1/2	21.7	3/4	16	9.53	32	36	9	45	48	0.224
※KCT27-060N	3/4	27.2	3/4	16	9.53	41	46	10	48	52.5	0.361
※KCT27-080N	3/4	27.2	1	22	10.39	41	46	10	51	54.5	0.399
※KCT34-080N	1	34.0	1	22	10.39	46	55	11	52	59	0.560
※KCT34-100N	1	34.0	1 1/4	28	12.70	46	55	11	55	60	0.603
※KCT43-100N	1 1/4	42.7	1 1/4	31	12.70	60	65	12	64	71	0.998
※KCT43-120N	1 1/4	42.7	1 1/2	34	12.70	60	65	12	64	71	1.031
※KCT48-120N	1 1/2	48.6	1 1/2	36	12.70	65	75	12	67	76	1.344
※KCT48-160N	1 1/2	48.6	2	40	15.88	65	75	12	71	76.5	1.505

注. 予告なしに、品質・性能・改善のため寸法を変更する事があります。

Note. Dimensions might be modified due to improvement of quality and performance.

ロング コネクタ

EXTENDED MALE CONNECTOR

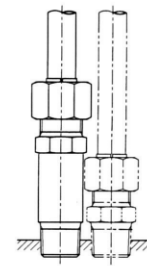
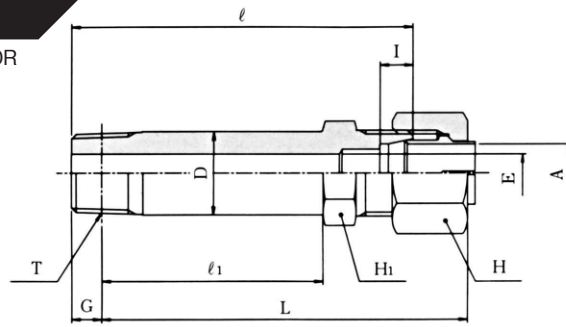

使用例
Example of Use

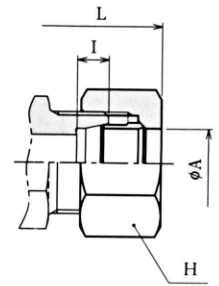

※印サイズの形状
※NS Type

単位：mm/Unit: mm

継手の呼び Part No.	適用管外径 Out. Dia. of Applied Pipe A		(R) T	E	基準径の位置 Engagement Fingertight G	六角対辺 Hex Width		I	D	l	l ₁	手締め(約) Fingertight Length (about) L	重量 Weight (kg)
	呼び径 Nominal sizes	外径 Out. Dia.				H ₁	H						
※KCC04-010N	4		1/8	2.5	3.97	12	12	6	10.5	46	30	49.5	0.034
KCC06-010E	6		1/8	4	3.97	14	14	7	10.5	63	41	69.5	0.048
KCC06-020E	6		1/4	4	6.01	14	14	7	14	69	45	73.5	0.074
KCC08-010E	8		1/8	4	3.97	17	17	7	10.5	65	42	71.5	0.063
KCC08-020E	8		1/4	6	6.01	17	17	7	14	70	45	74.5	0.083
KCC10-020E	10		1/4	7	6.01	17	19	7	14	71	46	76.5	0.088
KCC10-030E	10		3/8	8	6.35	19	19	7	17.5	72	46.5	77	0.121
KCC12-020E	12		1/4	7	6.01	19	22	7	14	71	46	76.5	0.099
KCC12-030E	12		3/8	9	6.35	19	22	7	17.5	72	46.5	77	0.124
KCC15-030E	15		3/8	9	6.35	24	27	7.5	17.5	81	52.5	87	0.184
KCC15-040E	15		1/2	12	8.16	24	27	7.5	22	86	56	90.5	0.219
KCC16-030E	16		3/8	9	6.35	27	30	7.5	17.5	81	52.5	87	0.206
KCC16-040E	16		1/2	12	8.16	27	30	7.5	22	86	56	90.5	0.250
KCC18-040E	18		1/2	12	8.16	27	32	8	22	86	56	90.5	0.254
KCC20-040E	20		1/2	12	8.16	30	36	8	22	90	58	94.5	0.306
KCC20-060E	20		3/4	16	9.53	30	36	8	27.5	92	58.5	95	0.373
KCC22-060E	22		3/4	16	9.53	32	36	9	27.5	93	59.5	96	0.366
KCC25-080E	25		1	20	10.39	36	41	10	34	99	63.5	102	0.570
KCC28-080E	28		1	22	10.39	41	46	10	34	104	66.5	107.5	0.626
KCC30-100E	30		1 1/4	25	12.70	46	46	10	42.5	109	68.5	111	0.920
KCC35-100E	35		1 1/4	28	12.70	46	55	11	43	113	72.5	118	0.936
※KCC11-020N	1/8	10.5	1/4	7	6.01	17	19	7	14	71	46	76.5	0.085
※KCC13-030N	1/4	13.8	3/8	9	6.35	22	24	7.5	17.5	81	52.5	86.5	0.139
※KCC17-030N	3/8	17.3	3/8	9	6.35	27	32	8	17.5	81	52.5	87	0.210
※KCC17-040N	3/8	17.3	1/2	12	8.16	27	32	8	22	86	56	90.5	0.255
※KCC21-060N	1/2	21.7	3/4	16	9.53	32	36	9	27.5	93	59.5	96	0.370
※KCC27-080N	3/4	27.2	1	22	10.39	41	46	10	34	104	66.5	107.5	0.929

注. 予告なしに、品質・性能・改善のため寸法を変更する事があります。

Note. Dimensions might be modified due to improvement of quality and performance.

平行ねじコネクタ (Oリング, ボンデットシール用)

STRAIGHT THREAD CONNECTOR
(for O-ring and bonded seal)

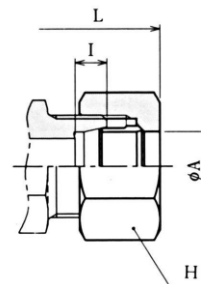
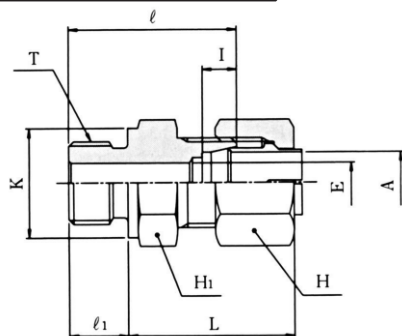

※印サイズの形状
※NS Type

単位: mm / Unit: mm

継手の呼び Part No.	適用管外径 Out. Dia. of Applied Pipe A		(G) T	E	六角対辺 Hex Width		I	K	l ₁	l	手じめ(約) Fingertight Length (about) L	重量 Weight (kg)
	呼び径 Nominal sizes	外径 Out. Dia.			H ₁	H						
※KC004-010N	4		1/8	2.5	14	12	6	14	8	23	22.5	0.022
KC006-010E	6		1/8	4	14	14	7	14	8	28	30.5	0.030
KC006-020E	6		1/4	4	19	14	7	19	12	33	31.5	0.048
KC006-030E	6		3/8	4	22	14	7	22	12	34	32.5	0.064
KC008-010E	8		1/8	4	17	17	7	14	8	28	30.5	0.042
KC008-020E	8		1/4	6	19	17	7	19	12	33	31.5	0.053
KC008-030E	8		3/8	6	22	17	7	22	12	34	32.5	0.069
KC010-020E	10		1/4	6	19	19	7	19	12	33	32.5	0.060
KC010-030E	10		3/8	8	22	19	7	22	12	34	33.5	0.073
KC010-040E	10		1/2	8	27	19	7	27	14	39	36.5	0.115
KC012-020E	12		1/4	6	19	22	7	19	12	33	32.5	0.069
KC012-030E	12		3/8	8	22	22	7	22	12	34	33.5	0.087
KC012-040E	12		1/2	10	27	22	7	27	14	39	36.5	0.119
KC015-030E	15		3/8	8	24	27	7.5	22	12	37	37.5	0.120
KC015-040E	15		1/2	12	27	27	7.5	27	14	41	39.5	0.141
KC016-030E	16		3/8	8	27	30	7.5	22	12	38	38.5	0.152
KC016-040E	16		1/2	12	27	30	7.5	27	14	41	39.5	0.164
KC018-040E	18		1/2	12	27	32	8	27	14	41	39.5	0.170
KC020-040E	20		1/2	12	30	36	8	27	14	42	40.5	0.217
KC020-060E	20		3/4	16	36	36	8	36	16	46	42.5	0.293
KC022-040E	22		1/2	12	32	36	9	27	14	43	41.5	0.217
KC022-060E	22		3/4	16	36	36	9	36	16	46	42.5	0.263
KC025-060E	25		3/4	16	36	41	10	36	16	46	43.5	0.311
KC025-080E	25		1	20	41	41	10	41	18	50	45.5	0.384
KC028-080E	28		1	22	41	46	10	41	18	52	48	0.424
KC030-080E	30		1	22	41	46	10	41	18	52	48.5	0.417
KC030-100E	30		1 1/4	25	50	46	10	50	20	57	51.5	0.604
KC035-100E	35		1 1/4	28	50	55	11	50	20	57	54.5	0.673
※KC038-120N	38		1 1/2	32	55	60	12	55	21	58	56.5	0.861
※KC040-120N	40		1 1/2	32	55	60	12	55	21	62	60.5	0.895
※KC042-120N	42		1 1/2	34	55	60	12	55	21	62	60.5	0.833
※KC050-160N	50		2	40	75	75	12	75	25	73	69.5	1.815
※KC011-010N	1/8	10.5	1/8	4	19	19	7	14	8	29	32.5	0.050
※KC011-020N	1/8	10.5	1/4	6	19	19	7	19	12	33	32.5	0.059
※KC013-020N	1/4	13.8	1/4	6	22	24	7.5	19	12	36	36	0.091
※KC013-030N	1/4	13.8	3/8	8	22	24	7.5	22	12	36	36	0.096
※KC017-030N	3/8	17.3	3/8	8	27	32	8	22	12	38	38.5	0.164
※KC017-040N	3/8	17.3	1/2	12	27	32	8	27	14	41	39.5	0.171
※KC021-040N	1/2	21.7	1/2	12	32	36	9	27	14	43	41.5	0.221
※KC021-060N	1/2	21.7	3/4	16	36	36	9	36	16	46	42.5	0.267
※KC027-060N	3/4	27.2	3/4	16	41	46	10	36	16	50	48	0.428
※KC027-080N	3/4	27.2	1	22	41	46	10	41	18	52	48	0.426
※KC034-080N	1	34.0	1	22	46	55	11	41	18	54	53.5	0.613
※KC034-100N	1	34.0	1 1/4	28	50	55	11	50	20	57	54.5	0.692
※KC043-100N	1 1/4	42.7	1 1/4	31	60	65	12	50	20	63	62.5	1.032
※KC043-120N	1 1/4	42.7	1 1/2	34	60	65	12	55	21	64	62.5	1.070
※KC048-120N	1 1/2	48.6	1 1/2	36	65	75	12	55	21	65	62.5	1.340
※KC048-160N	1 1/2	48.6	2	40	75	75	12	75	25	73	69.5	1.709

注. 1. 対応するガスケットはOリング, ボンデットシールが使用できます。ただし標準としては、付属しておりません。必要な場合は、その旨ご指示ください。
 2. 相手ポートの形状・寸法は60ページによります。(使用温度-20℃~120℃)
 3. G_{3/4}平行ねじ部のOリング溝径及び適用するOリングは、1990年改正前のJIS B 2351の寸法を採用しております。又、ポート入口径は、Oリングが破損するなどの不都合を改善するため、弊社推奨寸法のφ30.5を掲載いたしました。(60ページ) (JIS B 2351に規定されるポート入口径は新規規格、旧規格共φ29.8) 尚、新JIS規格品を御希望の場合は、その旨ご指示ください。
 4. 予告なしに、品質・性能・改善のため寸法を変更する事があります。
 Note. 1. O-ring and bonded-seal can be used as corresponding gasket. The gasket is not included in standard.
 2. Shape and dimension of mating port is shown in page 60. (range of working temperature: -20℃~120℃)
 3. Diameter of O-ring groove and applied O-ring on G_{3/4} straight thread is based on JIS B 2351 prior to modified in 1990. Port diameter of entrance is recommended φ30.5 to protect from damage of O-ring as shown in page 60. Port inlet diameter that is specified in JIS B2351 is φ29.8 for both new and old standard. (Please specify when require one of new Standard.)
 4. Dimensions might be modified due to improvement of quality and performance.

平行ねじコネクタ (Oリングシール用)

STRAIGHT THREAD CONNECTOR
(for O-SEAL)

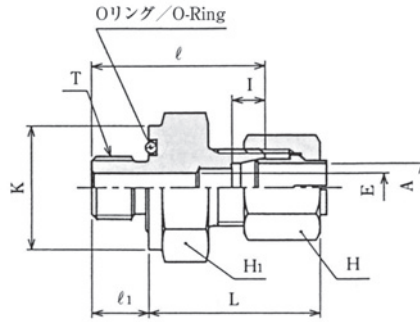

単位 : mm / Unit: mm

継手の呼び Part No.	適用管外径 Out. Dia. of Applied Pipe A	(G) T	E	六角対辺 Hex Width		I	K	ℓ ₁	ℓ	手締め(約) Fingertight Length (about) L	Oリング O-Ring JIS B 2401 -1B	重量 Weight (kg)
				H ₁	H							
KCD06-010E	6	1/8	4	22	14	7	22	8	30	32.5	P12.5	0.052
KCD06-020E	6	1/4	4	27	14	7	26	12	37	35.5	P16	0.095
KCD08-010E	8	1/8	4	22	17	7	22	8	30	32.5	P12.5	0.056
KCD08-020E	8	1/4	6	27	17	7	26	12	37	35.5	P16	0.093
KCD10-020E	10	1/4	6	27	19	7	26	12	37	36.5	P16	0.100
KCD10-030E	10	3/8	8	30	19	7	30	12	37	36.5	P20	0.118
KCD12-020E	12	1/4	6	27	22	7	26	12	37	36.5	P16	0.107
KCD12-030E	12	3/8	8	30	22	7	30	12	37	36.5	P20	0.128
KCD15-030E	15	3/8	8	30	27	7.5	30	12	39	39.5	P20	0.157
KCD15-040E	15	1/2	12	36	27	7.5	36	14	44	42.5	G25	0.215
KCD16-030E	16	3/8	8	30	30	7.5	30	12	39	39.5	P20	0.173
KCD16-040E	16	1/2	12	36	30	7.5	36	14	44	42.5	G25	0.238
KCD18-040E	18	1/2	12	36	32	8	36	14	44	42.5	G25	0.242
KCD20-040E	20	1/2	12	36	36	8	36	14	44	42.5	G25	0.272
KCD20-060E	20	3/4	16	41	36	8	41	16	48	44.5	G30	0.343
KCD22-040E	22	1/2	12	36	36	9	36	14	44	42.5	G25	0.263
KCD22-060E	22	3/4	16	41	36	9	41	16	48	44.5	G30	0.332
KCD25-060E	25	3/4	16	41	41	10	41	16	48	45.5	G30	0.369
KCD25-080E	25	1	22	50	41	10	50	18	53	48.5	P38	0.530
KCD28-080E	28	1	22	50	46	10	50	18	55	51	P38	0.560
KCD30-080E	30	1	22	50	46	10	50	18	55	51.5	P38	0.558
KCD30-100E	30	1 1/4	25	65	46	10	64	20	60	54.5	P48	0.925
KCD35-100E	35	1 1/4	28	65	55	11	64	20	60	57.5	P48	0.965

- 注. 1. OリングはJIS B 2401の1種B (NBR) を装着してあります。
(使用温度-20°C~120°C)
2. 予告なしに、品質・性能・改善のため寸法を変更する事があります。

- Note. 1. O-ring of JIS B 2401 (NBR) is installed. (range of working temperature: -20°C~120°C)
2. Dimensions might be modified due to improvement of quality and performance.

平行ねじロングコネクタ (Oリング, ボンデットシール用)

STRAIGHT THREAD EXTENDED MALE CONNECTOR ℓ
(for O-ring and bonded seal)

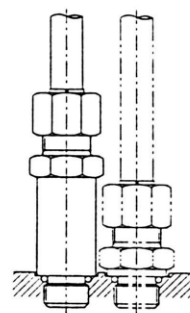
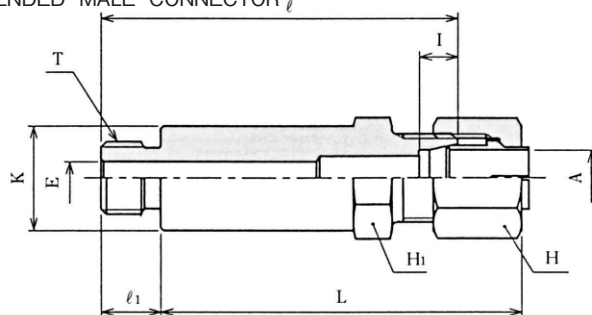

使用例 Example of Use 単位: mm / Unit: mm

継手の呼び Part No.	適用管外径 Out. Dia. of Applied Pipe A	(G) T	E	K	六角対辺 Hex Width		I	l_1	ℓ	手締め(約) Fingertight Length (about) L	Oリング O-Ring JIS B 2401 -1B	重量 Weight (kg)
					H1	H						
KCG08-020E	8	1/4	6	19	19	17	7	12	62	60.5	P11	0.112
KCG10-020E	10	1/4	6	19	19	19	7	12	66	65.5	P11	0.128
KCG10-030E	10	3/8	8	22	22	19	7	12	66	65.5	P14	0.164
KCG12-020E	12	1/4	6	19	19	22	7	12	67	66.5	P11	0.139
KCG12-030E	12	3/8	8	22	22	22	7	12	67	66.5	P14	0.176
KCG15-040E	15	1/2	12	27	27	27	7.5	14	71.5	77.5	P18	0.253
KCG16-030E	16	3/8	8	22	27	30	7.5	12	77	77.5	P14	0.246
KCG16-040E	16	1/2	12	27	27	30	7.5	14	79	77.5	P18	0.303
KCG18-040E	18	1/2	12	27	27	32	8	14	76	77.5	P18	0.293
KCG20-040E	20	1/2	12	27	30	36	8	14	83	81.5	P18	0.346
KCG20-060E	20	3/4	16	36	36	36	8	16	87	83.5	P24	0.540
KCG22-040E	22	1/2	12	27	32	36	9	14	81	82.5	P18	0.322
KCG22-060E	22	3/4	16	36	36	36	9	16	83	83.5	P24	0.499
KCG25-080E	25	1	20	41	41	41	10	18	94	89.5	P29	0.733

- 注. 1. 相手ポートの形状・寸法は60ページによります。
 2. この形式の管継手は、Oリング及びボンデットシールを標準としては付属しておりません。
 必要な場合はその旨ご指示ください。(使用温度-20°C~120°C)
 3. G $\frac{3}{4}$ 平行ねじ部のOリング溝径及び適用するOリングは、1990年改正前のJIS B 2351の寸法を採用しております。又、ポート入口径は、Oリングが破損するなどの不都合を改善するため、弊社推奨寸法の ϕ 30.5を掲載いたしました。(60ページ) (JIS B2351に規定されるポート入口径は新規格、旧規格共 ϕ 29.8)
 尚、新JIS規格品を御希望の場合は、その旨ご指定ください。
 4. 予告なしに、品質・性能・改善のため寸法を変更する事があります。

- Note. 1. Shape and dimension of mating port is shown in page 60.
 2. O-ring and bonded-seal can be used as corresponding gasket. The gasket is not included in standard. (range of working temperature: -20°C~120°C)
 3. Diameter of O-ring groove and applied O-ring on G $\frac{3}{4}$ straight thread is based on JIS B 2351 prior to modified in 1990. Port diameter of entrance is recommended ϕ 30.5 to protect from damage of O-ring as shown in page 60. Port inlet diameter that is specified in JIS B2351 is ϕ 29.8 for both new and old standard. (Please specify when require one of new Standard.)
 4. Dimensions might be modified due to improvement of quality and performance.

平行ねじコネクタ (銅ガスケット用)

STRAIGHT THREAD CONNECTOR
(for copper gasket)

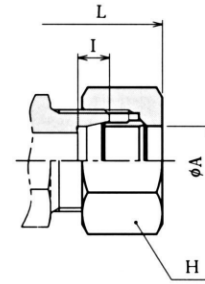
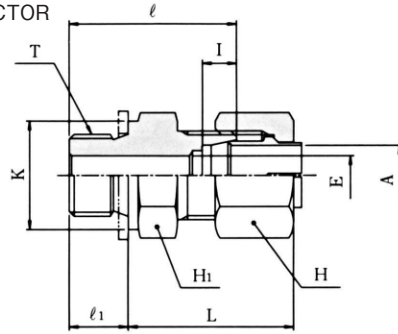

※印サイズの形状
※NS Type

単位：mm/Unit: mm

継手の呼び Part No.	適用管外径 Out. Dia. of Applied Pipe A		(G) T	E	六角対辺 Hex Width		I	K	l ₁	l	手締め(約) Fingertight Length (about) L	重量 Weight (kg)
	呼び径 Nominal sizes	外径 Out. Dia.			H ₁	H						
※KCJ04-010N	4		1/8	2.5	14	12	6	14	8	23	22.5	0.022
KCJ06-010E	6		1/8	4	14	14	7	14	8	28	30.5	0.031
KCJ06-020E	6		1/4	4	19	14	7	18	12	33	31.5	0.048
KCJ08-010E	8		1/8	4	17	17	7	14	8	28	30.5	0.042
KCJ08-020E	8		1/4	6	19	17	7	18	12	33	31.5	0.053
KCJ10-020E	10		1/4	6	19	19	7	18	12	33	32.5	0.060
KCJ10-030E	10		3/8	8	22	19	7	21.5	12	34	33.5	0.074
KCJ12-020E	12		1/4	6	19	22	7	18	12	33	32.5	0.069
KCJ12-030E	12		3/8	8	22	22	7	21.5	12	34	33.5	0.088
KCJ12-040E	12		1/2	10	27	22	7	25.5	14	39	36.5	0.119
KCJ15-030E	15		3/8	8	24	27	7.5	21.5	12	37	37.5	0.121
KCJ15-040E	15		1/2	12	27	27	7.5	25.5	14	41	39.5	0.141
KCJ16-040E	16		1/2	12	27	30	7.5	25.5	14	41	39.5	0.164
KCJ18-040E	18		1/2	12	27	32	8	25.5	14	41	39.5	0.170
KCJ20-060E	20		3/4	16	32	36	8	31.5	16	46	42.5	0.252
KCJ22-040E	22		1/2	12	32	36	9	25.5	14	43	41.5	0.217
KCJ22-060E	22		3/4	16	32	36	9	31.5	16	46	42.5	0.235
KCJ25-060E	25		3/4	16	36	41	10	31.5	16	46	43.5	0.307
KCJ25-080E	25		1	20	41	41	10	38	18	50	45.5	0.383
KCJ28-080E	28		1	22	41	46	10	38	18	52	48	0.422
KCJ30-080E	30		1	22	41	46	10	38	18	52	48.5	0.418
KCJ30-100E	30		1 1/4	25	50	46	10	48.5	20	57	51.5	0.605
KCJ35-100E	35		1 1/4	28	50	55	11	48.5	20	57	54.5	0.674
※KCJ38-120N	38		1 1/2	32	55	60	12	53.5	21	58	56.5	0.861
※KCJ40-120N	40		1 1/2	32	55	60	12	53.5	21	62	60.5	0.895
※KCJ42-120N	42		1 1/2	34	55	60	12	53.5	21	62	60.5	0.833
※KCJ50-160N	50		2	40	70	75	12	66	25	73	69.5	1.675
※KCJ11-010N	1/8	10.5	1/8	4	17	19	7	14	8	29	32.5	0.050
※KCJ11-020N	1/8	10.5	1/4	6	19	19	7	18	12	33	32.5	0.059
※KCJ13-020N	1/4	13.8	1/4	6	22	24	7.5	18	12	36	36	0.090
※KCJ13-030N	1/4	13.8	3/8	8	22	24	7.5	21.5	12	36	36	0.097
※KCJ17-030N	3/8	17.3	3/8	8	27	32	8	21.5	12	38	38.5	0.165
※KCJ17-040N	3/8	17.3	1/2	12	27	32	8	25.5	14	41	39.5	0.171
※KCJ21-040N	1/2	21.7	1/2	12	32	36	9	25.5	14	43	41.5	0.221
※KCJ21-060N	1/2	21.7	3/4	16	32	36	9	31.5	16	46	42.5	0.239
※KCJ27-060N	3/4	27.2	3/4	16	41	46	10	31.5	16	50	48	0.424
※KCJ27-080N	3/4	27.2	1	22	41	46	10	38	18	52	48	0.426
※KCJ34-080N	1	34.0	1	22	46	55	11	38	18	54	53.5	0.612
※KCJ34-100N	1	34.0	1 1/4	28	50	55	11	48.5	20	57	54.5	0.693
※KCJ43-100N	1 1/4	42.7	1 1/4	31	60	65	12	48.5	20	63	62.5	1.050
※KCJ43-120N	1 1/4	42.7	1 1/2	34	60	65	12	53.5	21	64	62.5	1.071
※KCJ48-120N	1 1/2	48.6	1 1/2	36	65	75	12	53.5	21	65	65.5	1.364
※KCJ48-160N	1 1/2	48.6	2	40	70	75	12	66	25	73	69.5	1.692

- 注. 1. 相手ポートの形状・寸法は60ページによります。
 2. ガスケットは標準付属いたしませんので必要の場合はその旨ご指定ください。
 3. 予告なしに、品質・性能・改善のため寸法を変更する事があります。

- Note. 1. Shape and dimension of mating port is shown in page 60.
 2. The gasket is not included in standard.
 3. Dimensions might be modified due to improvement of quality and performance.

コネクタ (めす)

FEMALE CONNECTOR

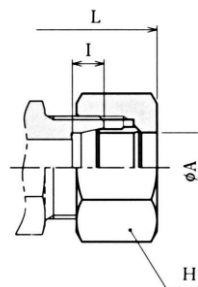
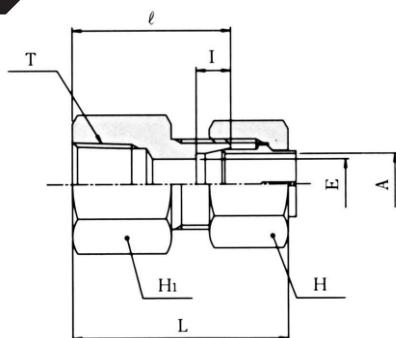

※印サイズの形状
※NS Type

単位：mm / Unit: mm

継手の呼び Part No.	適用管外径 Out. Dia. of Applied Pipe A		(Rc) T	E	六角対辺 Hex Width		I	ℓ	手締め(約) Fingertight Length (about) L	重量 Weight (kg)
	呼び径 Nominal sizes	外径 Out. Dia.			H1	H				
KSA06-010E	6		1/8	4	17	14	7	25	35.5	0.038
KSA06-020E	6		1/4	4	19	14	7	30	40.5	0.048
KSA08-010E	8		1/8	6	17	17	7	25	35.5	0.045
KSA08-020E	8		1/4	6	19	17	7	30	40.5	0.056
KSA10-020E	10		1/4	8	19	19	7	30	41.5	0.062
KSA10-030E	10		3/8	8	24	19	7	32	43.5	0.085
KSA12-020E	12		1/4	10	19	22	7	30	41.5	0.070
KSA12-030E	12		3/8	10	24	22	7	32	43.5	0.093
KSA15-030E	15		3/8	12	24	27	7.5	34	46.5	0.122
KSA15-040E	15		1/2	12	30	27	7.5	39	51.5	0.173
KSA16-030E	16		3/8	13	27	30	7.5	34	46.5	0.164
KSA16-040E	16		1/2	13	30	30	7.5	39	51.5	0.195
KSA18-040E	18		1/2	14	30	32	8	39	51.5	0.201
KSA20-040E	20		1/2	17	30	36	8	39	51.5	0.231
KSA20-060E	20		3/4	17	36	36	8	41	53.5	0.279
KSA22-060E	22		3/4	18	36	36	9	41	53.5	0.261
KSA25-060E	25		3/4	20	36	41	10	41	54.5	0.307
KSA25-080E	25		1	20	46	41	10	45	58.5	0.442
KSA28-080E	28		1	22	46	46	10	47	61	0.498
KSA30-080E	30		1	25	46	46	10	47	61.5	0.489
KSA30-100E	30		1 1/4	25	55	46	10	51	65.5	0.632
KSA35-100E	35		1 1/4	28	55	55	11	51	68.5	0.737
※KSA38-120N	38		1 1/2	32	65	60	12	51	70.5	1.030
※KSA40-120N	40		1 1/2	32	65	60	12	55	74.5	1.061
※KSA42-120N	42		1 1/2	34	65	60	12	55	74.5	1.030
※KSA50-160N	50		2	40	80	75	12	60	81.5	1.770
※KSA11-020N	1/8	10.5	1/4	8	19	19	7	30	41.5	0.060
※KSA13-030N	1/4	13.8	3/8	11	24	24	7.5	34	46	0.106
※KSA17-040N	3/8	17.3	1/2	14	30	32	8	39	51.5	0.201
※KSA21-060N	1/2	21.7	3/4	18	36	36	9	41	53.5	0.264
※KSA27-080N	3/4	27.2	1	22	46	46	10	47	61	0.501
※KSA34-100N	1	34.0	1 1/4	28	55	55	11	51	68.5	1.162
※KSA43-120N	1 1/4	42.7	1 1/2	34	65	65	12	55	75.5	1.162
※KSA48-160N	1 1/2	48.6	2	40	80	75	12	60	81.5	1.787

注. 予告なしに、品質・性能・改善のため寸法を変更する事があります。

Note. Dimensions might be modified due to improvement of quality and performance.

隔壁締付ソケット

BULKHEAD FEMALE CONNECTOR

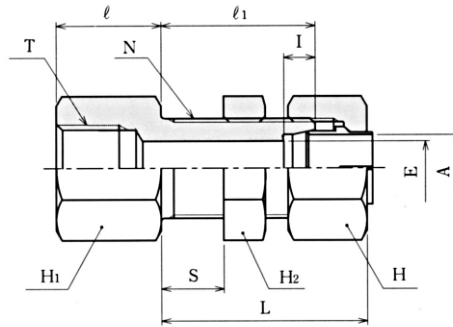

単位：mm/Unit: mm

継手の呼び Part No.	適用管 外径 Out. Dia. of Applied Pipe A	(Rc) T	E	六角対辺 Hex Width			I	l ₁	l	手締め(約) Fingertight Length (about) L	N	最大 Max S	重量 Weight (kg)
				H ₁	H ₂	H							
KSS06-010E	6	1/8	4	17	17	14	7	32	13	42.5	M12×1.5	13	0.060
KSS06-020E	6	1/4	4	17	17	14	7	32	13	42.5	M12×1.5	13	0.068
KSS08-010E	8	1/8	6	19	19	17	7	32	18	42.5	M14×1.5	13	0.095
KSS08-020E	8	1/4	6	19	19	17	7	32	18	42.5	M14×1.5	13	0.083
KSS10-020E	10	1/4	8	19	22	19	7	32	18	43.5	M16×1.5	13	0.099
KSS10-030E	10	3/8	8	24	22	19	7	32	20	43.5	M16×1.5	13	0.122
KSS12-020E	12	1/4	10	22	24	22	7	32	18	43.5	M18×1.5	13	0.112
KSS12-030E	12	3/8	10	24	24	22	7	32	20	43.5	M18×1.5	13	0.134
KSS15-030E	15	3/8	12	27	27	27	7.5	37	20	49.5	M22×1.5	15	0.181
KSS15-040E	15	1/2	12	30	27	27	7.5	37	25	49.5	M22×1.5	15	0.234
KSS16-030E	16	3/8	13	30	30	27	7.5	37	20	49.5	M24×1.5	15	0.265
KSS16-040E	16	1/2	13	30	30	30	7.5	37	25	49.5	M24×1.5	15	0.275
KSS18-040E	18	1/2	14	30	32	32	8	39	25	51.5	M26×1.5	15	0.299
KSS20-040E	20	1/2	17	36	36	36	8	39	25	51.5	M28×1.5	15	0.445
KSS20-060E	20	3/4	17	36	36	36	8	39	27	51.5	M28×1.5	15	0.369
KSS22-060E	22	3/4	18	36	36	36	9	39	27	51.5	M30×1.5	15	0.381
KSS25-060E	25	3/4	20	41	41	41	10	39	27	52.5	M35×1.5	15	0.539
KSS25-080E	25	1	20	46	41	41	10	39	31	52.5	M35×1.5	15	0.608
KSS28-080E	28	1	22	46	46	46	10	41	31	55	M38×1.5	15	0.706
KSS30-080E	30	1	25	46	46	46	10	41	31	55.5	M40×1.5	15	0.682
KSS30-100E	30	1 1/4	25	55	46	46	10	41	35	55.5	M40×1.5	15	0.830
KSS35-100E	35	1 1/4	28	55	50	55	11	43	35	60.5	M45×1.5	15	1.040

△注意：この形式の継手は隔壁貫通を目的としたもので、強振動の発生する箇所、或いは接続ホースの圧力変動が大きい箇所では配管クランプ等、振動対策（継手に掛かる発生応力を軽減するため）が必要です。

注. 予告なしに、品質・性能・改善のため寸法を変更する事があります。

△CAUTION: This type of fitting is designed to be used for wall penetration. When used in the place of strong vibration and / or pressure fluctuation, proper vibration measures such as fixing the piping by clamp are required.

Note. Dimensions might be modified due to improvement of quality and performance.

圧力計用コネクタ

CONNECTOR
For PRESSURE GAUGE

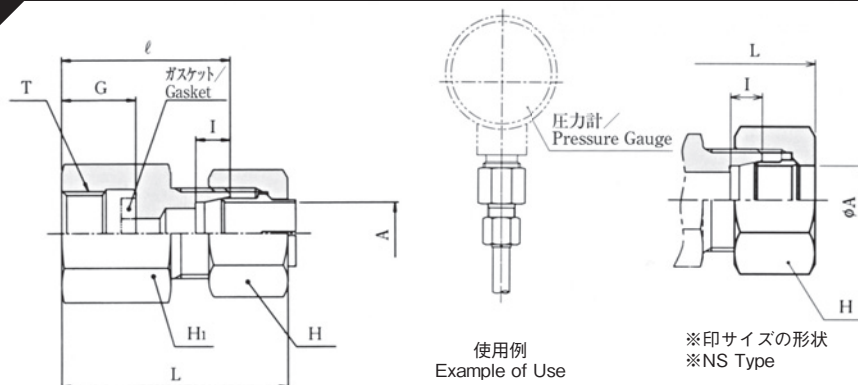

単位：mm / Unit: mm

継手の呼び Part No.	適用管外径 Out. Dia. of Applied Pipe A	(G) T	G	六角対辺 Hex Width		I	ℓ	手締め(約) Fingertight Length (about) L	ガスケットの 呼びKP-B 又はKP-D Nominal of Gasket KP-B or KP-D	重量 Weight (kg)
				H ₁	H					
※KGA04-020N	4	1/4	14	19	12	6	29	36.5	-01	0.046
※KGA04-030N	4	3/8	15	24	12	6	30	37.5	-02	0.070
KGA06-020E	6	1/4	14	19	14	7	32	42.5	-01	0.052
KGA06-030E	6	3/8	15	24	14	7	34	44.5	-02	0.078
KGA06-040E	6	1/2	16	30	14	7	36	46.5	-03	0.121
KGA08-020E	8	1/4	14	19	17	7	32	42.5	-01	0.058
KGA08-030E	8	3/8	15	24	17	7	34	44.5	-02	0.085
KGA08-040E	8	1/2	16	30	17	7	36	46.5	-03	0.128
KGA10-020E	10	1/4	14	19	19	7	32	43.5	-01	0.064
KGA10-030E	10	3/8	15	24	19	7	34	45.5	-02	0.090
KGA10-040E	10	1/2	16	30	19	7	36	47.5	-03	0.133
KGA12-020E	12	1/4	14	19	22	7	32	43.5	-01	0.073
KGA12-030E	12	3/8	15	24	22	7	34	45.5	-02	0.099
KGA12-040E	12	1/2	16	30	22	7	36	47.5	-03	0.140

- 注. 1. ガスケットは標準付属いたしませんので必要の場合はその旨ご指示ください。
 なお、この場合当社の標準ガスケットの寸法および材質は下記の通りです。
 2. 予告なしに、品質・性能・改善のため寸法を変更する事があります。

- Note. 1. Gasket are not provided as standard accessories. Please specify when required. For such case, ※dimension and material of lhara's standard gasket is as below.
 2. Dimensions might be modified due to improvement of quality and performance.

ガスケットの呼び Nominal of Gasket	ガスケットの寸法 Dimension			材 質 Material
	d	D	t	
KP-B-01	6	11	3	ク ロ ム 皮 Chrome leather
KP-B-02	6	14	3	
KP-B-03	6	18	3	
KP-D-01	6	11	2	りん脱酸銅 Phosphorous- deoxidized copper
KP-D-02	6	14	2	
KP-D-03	6	18	2	

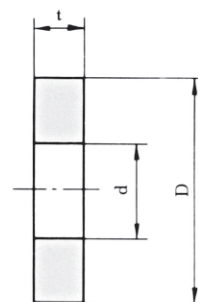

圧力計用コネクタ (Oリングシール用)

CONNECTOR
For PRESSURE GAUGE
(O-SEAL)

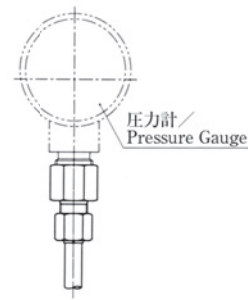
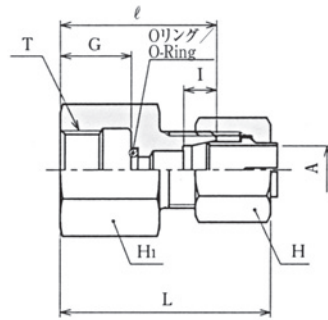

使用例
Example of Use

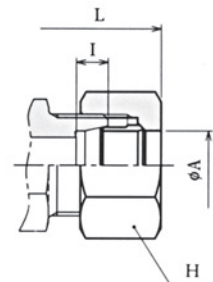

※印サイズの形状
※NS Type

単位 : mm / Unit: mm

継手の呼び Part No.	適用管外径 Out. Dia. of Applied Pipe A	(G) T	E	G	六角対辺 Hex Width		I	ℓ	手締め(約) Fingertight Length (about) L	JIS B2405 -1B Oリング o-ring	重量 Weight (kg)
					H ₁	H					
※KG004-020N	4	1/4	2.5	14	19	12	6	30	37.5	S6	0.049
※KG004-030N	4	3/8	2.5	15	24	12	6	31	38.5	P6	0.075
KG006-020E	6	1/4	4	14	19	14	7	33	43.5	S6	0.055
KG006-030E	6	3/8	4	15	24	14	7	35	45.5	P6	0.084
KG006-040E	6	1/2	4	16	30	14	7	36	46.5	P7	0.125
KG008-020E	8	1/4	6	14	19	17	7	33	43.5	S6	0.063
KG008-030E	8	3/8	6	15	24	17	7	35	45.5	P6	0.091
KG008-040E	8	1/2	6	16	30	17	7	36	46.5	P7	0.132
KG010-020E	10	1/4	6	14	19	19	7	36	47.5	S6	0.077
KG010-030E	10	3/8	6	15	24	19	7	33	44.5	P6	0.091
KG010-040E	10	1/2	6	16	30	19	7	35	46.5	P7	0.134
KG012-020E	12	1/4	6	14	19	22	7	36	47.5	S6	0.086
KG012-030E	12	3/8	6	15	24	22	7	35	46.5	P6	0.108
KG012-040E	12	1/2	6	16	30	22	7	36	47.5	P7	0.149

- 注. 1. OリングはJIS B 2401の種B (NBR) 又は、Sサイズを付属します。(使用温度-20℃~120℃)
2. 予告なしに、品質・性能・改善のため寸法を変更する事があります。

- Note. 1. O-ring of JIS B2401 (NBR) or S size is installed. (range of working temperature: -20℃~120℃)
2. Dimensions might be modified due to improvement of quality and performance.

溶接形コネクタ

WELD MALE CONNECTOR

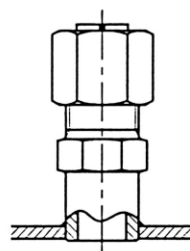
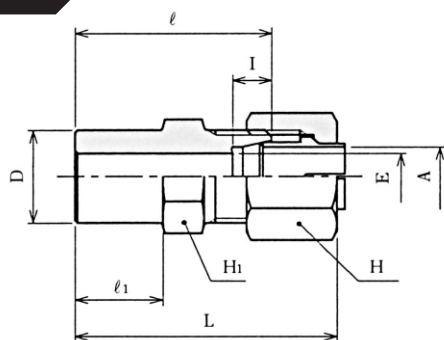

使用例
Example of Use

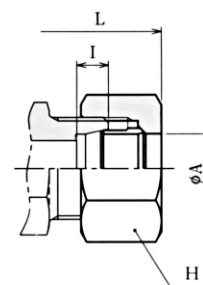

※印サイズの形状
※NS Type

単位：mm / Unit: mm

継手の呼び Part No.	適用管外径 Out. Dia. of Applied Pipe A		D	E	六角対辺 Hex Width		I	l ₁	l	手締め(約) Fingertight Length (about) L	重量 Weight (kg)
	呼び径 Nominal sizes	外径 Out. Dia.			H ₁	H					
KCW06-000E	6		12	4	14	14	7	11	29	39.5	0.035
KCW08-000E	8		14	6	17	17	7	15	34	44.5	0.053
KCW10-000E	10		16	8	17	19	7	15	34	45.5	0.062
KCW12-000E	12		18	10	19	22	7	15	34	45.5	0.075
KCW15-000E	15		21	12	24	27	7.5	18	40	52.5	0.127
KCW16-000E	16		22	13	27	30	7.5	22	44	56.5	0.165
KCW18-000E	18		25	14	27	32	8	22	44	56.5	0.198
KCW20-000E	20		28	17	30	36	8	22	46	58.5	0.239
KCW22-000E	22		28	18	32	36	9	22	46	58.5	0.227
KCW25-000E	25		33	20	36	41	10	26	51	64.5	0.340
KCW28-000E	28		36	22	41	46	10	28	55	69	0.463
KCW30-000E	30		39	25	41	46	10	28	55	69.5	0.448
KCW35-000E	35		43	28	46	55	11	28	56	73.5	0.635
※KCW38-000N	38		45	32	50	60	12	28	58	77.5	0.750
※KCW40-000N	40		46	32	55	60	12	30	65	84.5	0.877
※KCW50-000N	50		57	40	65	75	12	30	70	91.5	1.448
※KCW11-000N	1/8	10.5	16	8	17	19	7	15	34	45.5	0.058
※KCW13-000N	1/4	13.8	19	11	22	24	7.5	18	40	52	0.101
※KCW17-000N	3/8	17.3	24	14	27	32	8	22	44	56.5	0.181
※KCW21-000N	1/2	21.7	28	18	32	36	9	22	46	58.5	0.231
※KCW27-000N	3/4	27.2	30	22	41	46	10	25	52	66	0.381
※KCW34-000N	1	34.0	40	28	46	55	11	28	56	73.5	0.597
※KCW43-000N	1 1/4	42.7	47	34	60	65	12	28	65	84.5	1.042
※KCW48-000N	1 1/2	48.6	55	40	65	75	12	30	70	91.5	1.428

注. 1. この形式の継手本体材質は、S25C又は相当品を使用しています。
2. 予告なしに、品質・性能・改善のため寸法を変更する事があります。

Note. 1. The material of this type of fitting body is JIS S25C or equivalent.
2. Dimensions might be modified due to improvement of quality and performance.

エルボ

UNION ELBOW

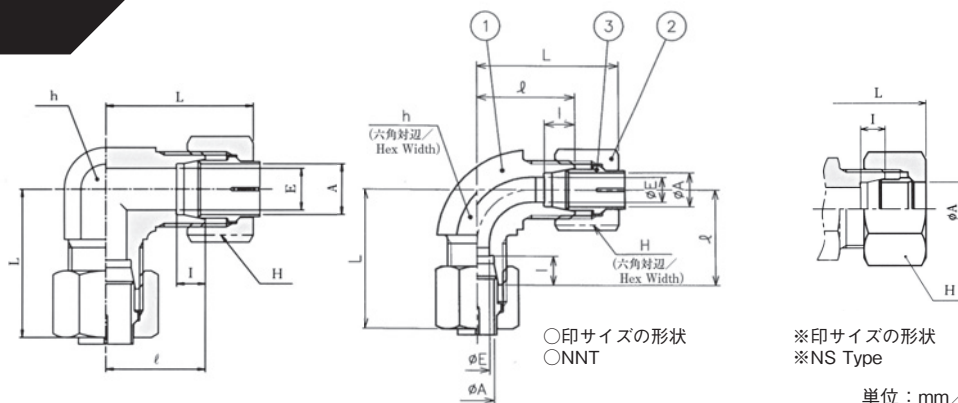

単位：mm / Unit: mm

継手の呼び Part No.	適用管外径 Out. Dia. of Applied Pipe A		E	二面幅 Width across flats h	六角対辺 Hex Width H	I	ℓ	手締め(約) Fingertight Length (about) L	重量 Weight (kg)
	呼び径 Nominal sizes	外径 Out. Dia.							
KLA06-000E	6		4	14	14	7	20	30.5	0.048
○KLA08-000KNNT	8		6	17	17	7	23	33.5	0.081
○KLA10-000KNNT	10		8	17	19	7	23	34.5	0.089
○KLA12-000KNNT	12		10	19	22	7	24	35.5	0.116
KLA15-000E	15		12	24	27	7.5	29	41.5	0.221
KLA16-000E	16		13	27	30	7.5	32	44.5	0.319
KLA18-000E	18		14	27	32	8	32	44.5	0.325
KLA20-000E	20		17	30	36	8	33	45.5	0.405
KLA22-000E	22		18	32	36	9	34	46.5	0.403
KLA25-000E	25		20	36	41	10	36	49.5	0.584
KLA28-000E	28		22	41	46	10	41	55	0.870
KLA30-000E	30		25	41	46	10	41	55.5	0.812
KLA35-000E	35		28	46	55	11	46	63.5	1.169
※KLA38-000N	38		32	50	60	12	50	69.5	1.518
※KLA40-000N	40		32	55	60	12	55	74.5	1.802
※KLA42-000N	42		34	55	60	12	55	74.5	1.690
※KLA50-000N	50		40	65	75	12	62	83.5	2.964
○※KLA11-000KNNT	1/8	10.5	8	17	19	7	23	34.5	0.089
※KLA13-000N	1/4	13.8	11	22	24	7.5	28	40	0.172
※KLA17-000N	3/8	17.3	14	27	32	8	32	44.5	0.327
※KLA21-000N	1/2	21.7	18	32	36	9	34	46.5	0.414
※KLA27-000N	3/4	27.2	22	41	46	10	41	55	0.876
※KLA34-000N	1	34.0	28	46	55	11	46	63.5	1.207
※KLA43-000N	1 1/4	42.7	34	60	65	12	57	77.5	2.263
※KLA48-000N	1 1/2	48.6	40	65	75	12	62	83.5	2.998

注. 予告なしに、品質・性能・改善のため寸法を変更する事があります。

Note. Dimensions might be modified due to improvement of quality and performance.

隔壁締付エルボ

BULKHEAD UNION ELBOW

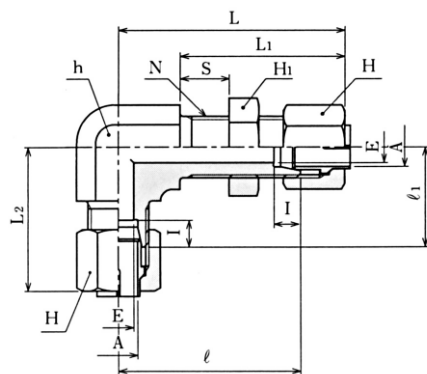

単位：mm / Unit: mm

継手の呼び Part No.	適用管 外径 Out. Dia. of Applied Pipe A	E	二面幅 Width across flats h	六角対辺 Hex Width		I	ℓ ₁	ℓ	手締め(約) Fingertight Length (about) L			N	最大 Max S	重量 Weight (kg)
				H ₁	H				L ₁	L ₂	L			
KSL06-000E	6	4	17	17	14	7	23	45	42.5	33.5	55.5	M12×1.5	13	0.102
KSL08-000E	8	6	19	19	17	7	24	46	42.5	34.5	56.5	M14×1.5	13	0.132
KSL10-000E	10	8	22	22	19	7	26	48	43.5	37.5	59.5	M16×1.5	13	0.178
KSL12-000E	12	10	24	24	22	7	27	49	43.5	38.5	60.5	M18×1.5	13	0.217
KSL15-000E	15	12	27	27	27	7.5	31	57	49.5	43.5	69.5	M22×1.5	15	0.336
KSL16-000E	16	13	30	30	30	7.5	33	59	49.5	45.5	71.5	M24×1.5	15	0.449
KSL18-000E	18	14	32	32	32	8	33	63	51.5	45.5	75.5	M26×1.5	15	0.504
KSL20-000E	20	17	32	36	36	8	33	65	51.5	45.5	77.5	M28×1.5	15	0.561
KSL22-000E	22	18	36	36	36	9	36	65	51.5	48.5	77.5	M30×1.5	15	0.672
KSL25-000E	25	20	41	41	41	10	39	68	52.5	52.5	81.5	M35×1.5	15	0.982
KSL28-000E	28	22	41	46	46	10	41	70	55	55	84	M38×1.5	15	1.114
KSL30-000E	30	25	46	46	46	10	46	74	55.5	60.5	88.5	M40×1.5	15	1.222

⚠注意：この形式の継手は障壁貫通を目的としたもので、強振動の発生する箇所、或いは接続ホースの圧力変動が大きい箇所では配管クランプ等、振動対策（継手に掛かる発生応力を軽減するため）が必要です。

注. 予告なしに、品質・性能・改善のため寸法を変更する事があります。

⚠CAUTION: This type of fitting is designed to be used for wall penetration. When used in the place of strong vibration and / or pressure fluctuation, proper vibration measures such as fixing the piping by clamp are required.

Note. Dimensions might be modified due to improvement of quality and performance.

エルボ ニップル

MALE ELBOW

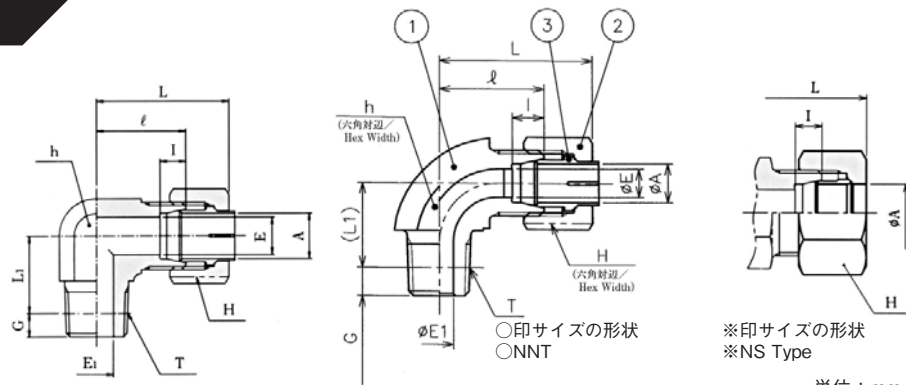

単位：mm/Unit: mm

継手の呼び Part No.	適用管外径 Out. Dia. of Applied Pipe A		(R) T	E	E ₁	基準径の位置 Engagement Fingertight G	二面幅 Width across flats h	六角対辺 Hex Width H	I	ℓ	手締め(約) Fingertight Length (about) L	(約) (about) L ₁	重量 Weight (kg)
	呼び径 Nominal sizes	外径 Out. Dia.											
※KLN04-010N	4		1/8	2.5	4	3.97	12	12	6	15	22.5	13	0.025
KLN06-010E	6		1/8	4	4	3.97	14	14	7	20	30.5	14	0.039
○KLN06-020KNNT	6		1/4	4	4.5	6.01	17	14	7	23	33.5	17	0.058
KLN06-030E	6		3/8	4	9	6.35	19	14	7	24	34.5	19.5	0.082
KLN08-010E	8		1/8	6	4	3.97	17	17	7	23	33.5	16	0.063
○KLN08-020KNNT	8		1/4	6	6.5	6.01	17	17	7	23	33.5	18	0.064
KLN08-030E	8		3/8	6	9	6.35	19	17	7	24	34.5	19.5	0.086
○KLN10-020KNNT	10		1/4	8	7.5	6.01	17	19	7	23	34.5	19	0.066
○KLN10-030KNNT	10		3/8	8	8.5	6.35	19	19	7	24	35.5	19.5	0.085
KLN10-040E	10		1/2	8	12	8.16	24	19	7	29	40.5	26	0.137
○KLN12-020KNNT	12		1/4	10	7.5	6.01	19	22	7	24	35.5	20	0.090
○KLN12-030KNNT	12		3/8	10	9.5	6.35	19	22	7	24	35.5	20.5	0.093
KLN12-040E	12		1/2	10	12	8.16	24	22	7	29	40.5	26	0.164
KLN15-030E	15		3/8	12	9	6.35	24	27	7.5	29	41.5	23.5	0.172
KLN15-040E	15		1/2	12	12	8.16	24	27	7.5	29	41.5	26	0.182
KLN16-030E	16		3/8	13	9	6.35	27	30	7.5	32	44.5	25.5	0.247
KLN16-040E	16		1/2	13	12	8.16	27	30	7.5	32	44.5	27	0.255
KLN18-030E	18		3/8	14	9	6.35	27	32	8	32	44.5	27.5	0.256
KLN18-040E	18		1/2	14	12	8.16	27	32	8	32	44.5	30	0.263
KLN20-040E	20		1/2	17	12	8.16	30	36	8	33	45.5	32	0.330
KLN20-060E	20		3/4	17	16	9.53	30	36	8	33	45.5	30.5	0.330
KLN22-040E	22		1/2	18	12	8.16	32	36	9	34	46.5	32	0.344
KLN22-060E	22		3/4	18	16	9.53	32	36	9	34	46.5	32.5	0.353
KLN25-060E	25		3/4	20	16	9.53	36	41	10	36	49.5	33.5	0.493
KLN25-080E	25		1	20	22	10.39	36	41	10	36	49.5	35.5	0.499
KLN28-060E	28		3/4	22	16	9.53	41	46	10	41	55	37.5	0.740
KLN28-080E	28		1	22	22	10.39	41	46	10	41	55	39.5	0.740
KLN30-080E	30		1	25	22	10.39	41	46	10	41	55.5	39.5	0.706
KLN30-100E	30		1 1/4	25	31	12.70	46	46	10	46	60.5	42.5	0.922
KLN35-100E	35		1 1/4	28	31	12.70	46	55	11	46	63.5	45.5	0.926
※KLN38-120N	38		1 1/2	32	36	12.70	50	60	12	50	69.5	48.5	1.146
※KLN40-120N	40		1 1/2	32	36	12.70	55	60	12	55	74.5	49.5	1.141
※KLN42-120N	42		1 1/2	34	36	12.70	55	60	12	55	74.5	49.5	1.365
※KLN50-160N	50		2	40	46	15.88	65	75	12	62	83.5	58	2.293
※KLN11-010N	1/8	10.5	1/8	8	4	3.97	17	19	7	23	34.5	17	0.065
○※KLN11-020KNNT	1/8	10.5	1/4	8	7.5	6.01	17	19	7	23	34.5	19	0.066
※KLN13-020N	1/4	13.8	1/4	11	7	6.01	22	24	7.5	28	40	22	0.136
※KLN13-030N	1/4	13.8	3/8	11	9	6.35	22	24	7.5	28	40	22.5	0.139
※KLN17-030N	3/8	17.3	3/8	14	9	6.35	27	32	8	32	44.5	27.5	0.262
※KLN17-040N	3/8	17.3	1/2	14	12	8.16	27	32	8	32	44.5	30	0.264
※KLN21-040N	1/2	21.7	1/2	18	12	8.16	32	36	9	34	46.5	32	0.384
※KLN21-060N	1/2	21.7	3/4	18	16	9.53	32	36	9	34	46.5	32.5	0.357
※KLN27-060N	3/4	27.2	3/4	22	16	9.53	41	46	10	41	55	37.5	0.725
※KLN27-080N	3/4	27.2	1	22	22	10.39	41	46	10	41	55	39.5	0.748
※KLN34-080N	1	34.0	1	28	22	10.39	46	55	11	46	63.5	44.5	0.997
※KLN34-100N	1	34.0	1 1/4	28	31	12.70	46	55	11	46	63.5	44.5	0.945
※KLN43-100N	1 1/4	42.7	1 1/4	34	31	12.70	60	65	12	57	77.5	51.5	1.853
※KLN43-120N	1 1/4	42.7	1 1/2	34	36	12.70	60	65	12	57	77.5	51.5	1.805
※KLN48-120N	1 1/2	48.6	1 1/2	40	36	12.70	65	75	12	62	83.5	57.5	2.443
※KLN48-160N	1 1/2	48.6	2	40	46	15.88	65	75	12	62	83.5	58	3.310

注. 予告なしに、品質・性能・改善のため寸法を変更する事があります。

Note. Dimensions might be modified due to improvement of quality and performance.

ロング エルボ

EXTENDED MALE ELBOW

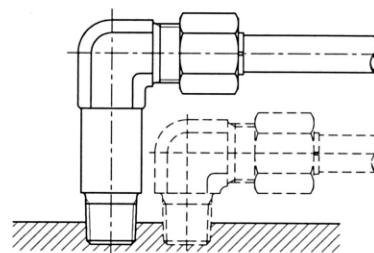
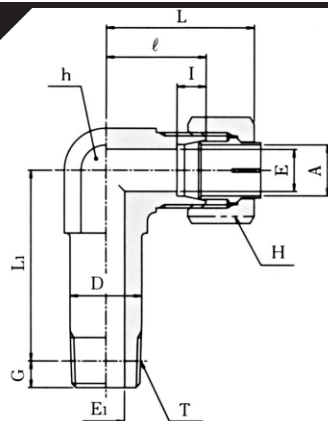

使用例
Example of Use

単位：mm / Unit: mm

継手の呼び Part No.	適用管 外径 Out. Dia. of Applied Pipe A	(R) T	E	E ₁	基準径の位置 Engagement Fingertight G	二面幅 Width across flats h	六角対辺 Hex Width H	I	D	ℓ	手締め(約) Fingertight Length (about) L	(約) L ₁	重量 Weight (kg)
KLL06-010E	6	1/8	4	4	3.97	14	14	7	12	20	30.5	36	0.058
KLL06-020E	6	1/4	4	7	6.01	17	14	7	16	23	33.5	40	0.093
KLL08-020E	8	1/4	6	7	6.01	17	17	7	16	23	33.5	43	0.103
KLL08-030E	8	3/8	6	9	6.35	19	17	7	18	24	34.5	48.5	0.121
KLL10-020E	10	1/4	8	7	6.01	17	19	7	16	23	34.5	46	0.113
KLL12-020E	12	1/4	10	7	6.01	19	22	7	18	24	35.5	52	0.156
KLL12-030E	12	3/8	10	9	6.35	19	22	7	18	24	35.5	53	0.156
KLL15-030E	15	3/8	12	9	6.35	22	27	7.5	23	29	41.5	61.5	0.259
KLL15-040E	15	1/2	12	12	8.16	22	27	7.5	23	29	41.5	67	0.261
KLL16-030E	16	3/8	13	9	6.35	24	30	7.5	24	32	44.5	68.5	0.331
KLL16-040E	16	1/2	13	12	8.16	24	30	7.5	24	32	44.5	70	0.329
KLL18-040E	18	1/2	14	12	8.16	27	32	8	26	32	44.5	77	0.425
KLL20-040E	20	1/2	17	12	8.16	30	36	8	28	33	45.5	84	0.538
KLL20-060E	20	3/4	17	16	9.53	30	36	8	28	33	45.5	82.5	0.507
KLL22-060E	22	3/4	18	16	9.53	32	36	9	30	34	46.5	83.5	0.566
KLL25-060E	25	3/4	20	16	9.53	36	41	10	35	36	49.5	90.5	0.974
KLL25-080E	25	1	20	22	10.39	36	41	10	35	36	49.5	91.5	0.898
KLL28-080E	28	1	22	22	10.39	41	46	10	40	41	55	104.5	1.195
KLL30-100E	30	1 1/4	25	31	12.70	46	46	10	44	46	60.5	104.5	1.242
KLL35-100E	35	1 1/4	28	31	12.70	46	55	11	44	46	63.5	121.5	1.401

注. 予告なしに、品質・性能・改善のため寸法を変更する事があります。

Note. Dimensions might be modified due to improvement of quality and performance.

Oリングガスケット形エルボニップル

O-SEAL MALE ELBOW

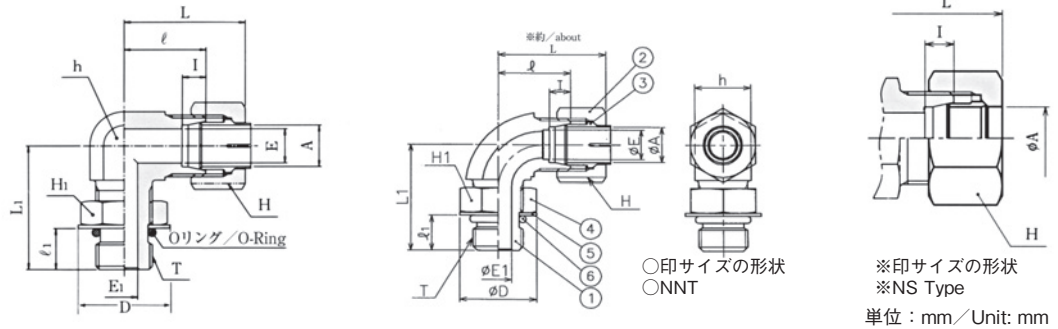

継手の呼び Part No.	適用管外径 Out. Dia. of Applied Pipe A	(G) T	E	E ₁	二面幅 Width across flats h	六角対辺 Hex Width		I	ℓ ₁	ℓ	L ₁	手締め(約) Fingertight Length (about) L	D	Oリング O-Ring JIS B2401 -1B	重量 Weight (kg)
						H ₁	H								
KLO06-010E	6	1/8	4	4	14	14	14	7	10	20	30	30.5	17	P8	0.052
○KLO08-020KNNT	8	1/4	6	6.5	17	19	17	7	12	23	34	33.5	20	P11	0.079
○KLO10-020KNNT	10	1/4	8	7.5	17	19	19	7	12	23	35	34.5	20	P11	0.086
○KLO10-030KNNT	10	3/8	8	8.5	19	22	19	7	12	24	36	35.5	25.6	P14	0.109
○KLO12-020KNNT	12	1/4	10	7.5	19	19	22	7	12	24	36	35.5	20	P11	0.104
○KLO12-030KNNT	12	3/8	10	9.5	19	22	22	7	12	24	36	35.5	25.6	P14	0.115
KLO12-040E	12	1/2	10	12	24	27	22	7	16	24	46	35.5	29	P18	0.182
KLO15-030E	15	3/8	12	9	24	22	27	7.5	12	29	40	41.5	25.6	P14	0.158
KLO15-040E	15	1/2	12	12	24	27	27	7.5	16	29	46	41.5	29	P18	0.215
KLO16-030E	16	3/8	13	9	24	22	27	7.5	12	32	40	44.5	25.6	P14	0.195
KLO16-040E	16	1/2	13	12	24	27	30	7.5	16	32	46	44.5	29	P18	0.244
KLO18-040E	18	1/2	14	12	30	27	32	8	16	32	52	44.5	29	P18	0.343
KLO20-040E	20	1/2	17	12	30	27	36	8	16	33	52	45.5	29	P18	0.385
KLO20-060E	20	3/4	17	16	30	36	36	8	17	33	52	45.5	38	P24	0.401
KLO22-060E	22	3/4	18	16	32	36	36	9	17	34	52	46.5	38	P24	0.416
KLO25-060E	25	3/4	20	16	36	36	41	10	17	36	60	49.5	38	P24	0.590
KLO25-080E	25	1	20	22	36	41	41	10	21	36	62	49.5	44	P29	0.591
KLO28-080E	28	1	22	22	41	41	46	10	21	41	62	55	44	P29	0.807
KLO30-080E	30	1	25	22	41	41	46	10	21	41	66	55.5	44	P29	0.807
KLO30-100E	30	1 1/4	25	31	41	50	46	10	21	44	66	58.5	58	P38	0.774
KLO35-100E	35	1 1/4	28	31	46	50	55	11	21	46	66	63.5	58	P38	1.018
※KLO38-120N	38	1 1/2	32	36	50	55	60	12	21	50	73	69.5	64	P44	1.277

- 注. 1. 相手ポートの形状・寸法は60ページによります。
 2. OリングはJIS B 2401の1種B (NBR) 装着してあります。(使用温度-20℃~120℃)
 3. G³/₄平行ねじ部のOリング溝径及び適用するOリングは、1990年改正前のJIS B 2351の寸法を採用しております。又、ポート入口径は、Oリングが破損するなどの不都合を改善するため、弊社推奨寸法のφ30.5を掲載いたしました。(60ページ) (JIS B2351に規定されるポート入口径は新規格、旧規格共φ29.8) 尚、新JIS規格品を御希望の場合は、その旨ご指定ください。
 4. 予告なしに、品質・性能・改善のため寸法を変更する事があります。

- Note. 1. Shape and dimension of mating port is shown in page 60.
 2. O-ring of JIS B 2401 (NBR) is installed. (range of working temperature: -20°C~120°C)
 3. Diameter of O-ring groove and applied O-ring on G³/₄ straight thread is based on JIS B 2351 prior to modified in 1990. Port diameter of entrance is recommended φ30.5 to protect from damage of O-ring as shown in page 60. Port inlet diameter that is specified in JIS B2351 is φ29.8 for both new and old standard. (Please specify when require one of new Standard.)
 4. Dimensions might be modified due to improvement of quality and performance.

ねじサイズ/Thread Size	定格圧力/Rated Pressure
G ¹ / ₈	35MPa
G ¹ / ₄	〃
G ³ / ₈	〃
G ¹ / ₂	〃
G ³ / ₄	〃
G ¹	〃
G ¹ / ₄	21MPa
G ¹ / ₂	〃

KLOのOリングポート側組付要領 / Assembly figure of O-ring Port

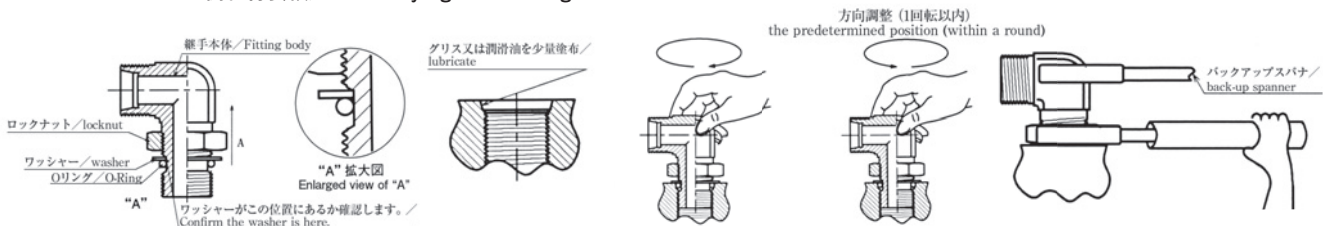

1. ロックナットの端面が継手本体のOリング溝から外れるまで移動(A方向)させます。
1. Move the locknut until coming out of O-ring groove. (to A-direction)
2. 相手ポート面にバックアップワッシャーが当たるまでねじ込みます。
2. Screw in to the mating port until the back-up washer bottoms.
3. 所定の位置まで反転(1回転以内)し方向を調整します。
3. Adjust the direction by reversing (within a round) up to the predetermined position.
4. 継手本体を固定しロックナットを締付けます。
4. Fix the fitting body with back-up spanner and tighten the locknut.

リングガasket形ロングエルボニップル

O-SEAL EXTENDED MALE ELBOW

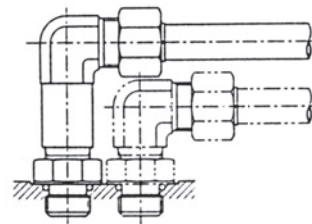
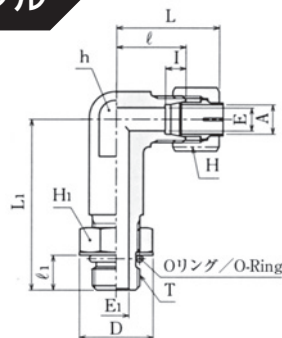

使用例
Example of Use

単位：mm/Unit: mm

継手の呼び Part No.	適用管外径 Out. Dia. of Applied Pipe A	(G) T	E	E ₁	二面幅 Width across flats h	六角対辺 Hex Width		I	l ₁	l	L ₁	手締め(約) Fingertight Length (about) L	D	JISB2401 -1B Oリング O-ring	重量 Weight (kg)
						H ₁	H								
KLG08-020E	8	1/4	6	6	17	19	17	7	12	23	54	33.5	20	P11	0.142
KLG10-020E	10	1/4	8	6	19	19	19	7	12	24	59	35.5	20	P11	0.153
KLG10-030E	10	3/8	8	9	19	22	19	7	12	24	59	35.5	25.6	P14	0.156
KLG12-020E	12	1/4	10	6	22	19	22	7	12	25	67	36.5	20	P11	0.221
KLG12-030E	12	3/8	10	9	22	22	22	7	12	25	67	36.5	25.6	P14	0.225
KLG15-040E	15	1/2	12	12	24	27	27	7.5	16	29	77	41.5	29	P18	0.306
KLG16-030E	16	3/8	13	9	24	22	30	7.5	12	32	75	44.5	25.6	P14	0.321
KLG16-040E	16	1/2	13	12	24	27	30	7.5	16	32	79	44.5	29	P18	0.331
KLG18-040E	18	1/2	14	12	30	27	32	8	16	32	83	44.5	29	P18	0.479
KLG20-040E	20	1/2	17	12	30	27	36	8	16	33	90	45.5	29	P18	0.443
KLG20-060E	20	3/4	17	16	30	36	36	8	17	33	91	45.5	38	P24	0.527
KLG22-040E	22	1/2	18	12	32	27	36	9	16	34	88	46.5	29	P18	0.598
KLG22-060E	22	3/4	18	16	32	36	36	9	17	34	88	46.5	38	P24	0.584
KLG25-080E	25	1	20	22	36	41	41	10	21	36	108	49.5	44	P29	0.801

- 注. 1. 相手ポートの形状・寸法は60ページによります。
 2. OリングはJIS B 2401の1種(NBR)装着してあります。(使用温度-20℃~120℃)
 3. G³/₄平行ねじ部のOリング溝径及び適用するOリングは、1990年改正前のJIS B 2351の寸法を採用しております。又、ポート入口径は、Oリングが破損するなどの不都合を改善するため、弊社推奨寸法のφ30.5を掲載いたしました。(60ページ) (JIS B2351に規定されるポート入口径は新規格、旧規格共φ29.8) 尚、新JIS規格品を御希望の場合は、その旨ご指定ください。
 4. 予告なしに、品質・性能・改善のため寸法を変更する事があります。

- Note. 1. Shape and dimension of mating port is shown in page 60.
 2. O-ring of JIS B 2401 (NBR) is installed. (range of working temperature: -20℃~120℃)
 3. Diameter of O-ring groove and applied O-ring on G³/₄ straight thread is based on JIS B 2351 prior to modified in 1990. Port diameter of entrance is recommended φ30.5 to protect from damage of O-ring as shown in page 60. Port inlet diameter that is specified in JIS B2351 is φ29.8 for both new and old standard. (Please specify when require one of new Standard.)
 4. Dimensions might be modified due to improvement of quality and performance.

ねじサイズ/Thread Size	定格圧力/Rated Pressure
G ¹ / ₈	35MPa
G ¹ / ₄	〃
G ³ / ₈	〃
G ¹ / ₂	〃
G ³ / ₄	〃
G1	〃
G1 ¹ / ₄	21MPa
G1 ¹ / ₂	〃

KLGのOリングポート側組付要領/Assembly figure of O-ring Port

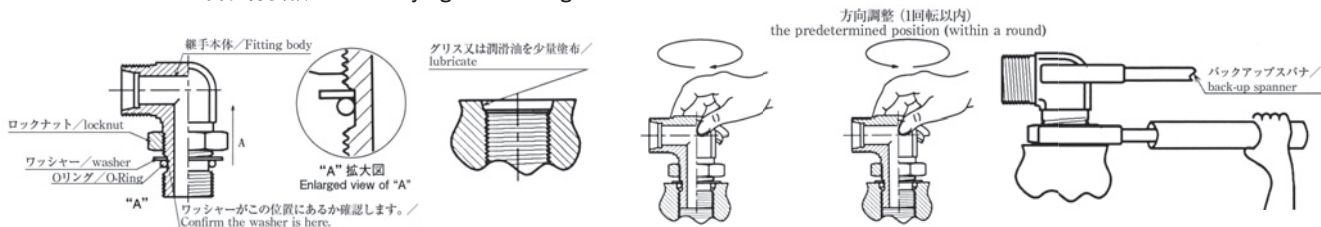

1. ロックナットの端面が継手本体のOリング溝から外れるまで移動(A方向)させます。
1. Move the locknut until coming out of O-ring groove. (to A-direction)
2. 相手ポート面にバックアップワッシャーが当たるまでねじ込みます。
2. Screw in to the mating port until the back-up washer bottoms.
3. 所定の位置まで反転(1回転以内)し方向を調整します。
3. Adjust the direction by reversing (within a round) up to the predetermined position.
4. 継手本体を固定しロックナットを締付けます。
4. Fix the fitting body with back-up spanner and tighten the locknut.

方向調整エルボ

ADJUSTABLE ELBOW

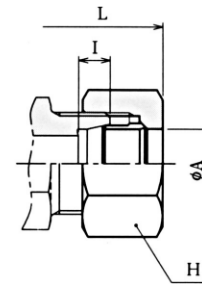
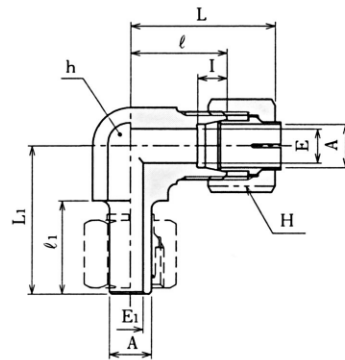

※印サイズの形状
※NS Type

単位：mm/Unit: mm

継手の呼び Part No.	適用管外径 Out. Dia. of Applied Pipe A	E	E ₁	二面幅 Width across flats h	六角対辺 Hex Width H	I	ℓ	ℓ ₁	手締め(約) Fingertight Length (about) L	L ₁	重量 Weight (kg)
KLC06-000E	6	4	3	17	14	7	22	22	32.5	31	0.071
KLC08-000E	8	6	5	17	17	7	23	21	33.5	32	0.079
KLC10-000E	10	8	6	17	19	7	23	22	34.5	35	0.082
KLC12-000E	12	10	8	19	22	7	24	22.5	35.5	37	0.093
KLC15-000E	15	12	10	27	27	7.5	32	24.5	44.5	43	0.237
KLC16-000E	16	13	11	27	30	7.5	32	24.5	44.5	43	0.255
KLC18-000E	18	14	12	27	32	8	32	24.5	44.5	43	0.263
KLC20-000E	20	17	14	30	36	8	33	26	45.5	45	0.326
KLC22-000E	22	18	14	32	36	9	34	27	46.5	46	0.349
KLC25-000E	25	20	17	36	41	10	36	29.5	49.5	49	0.481
KLC28-000E	28	22	18	41	46	10	41	29.5	55	53	0.747
KLC30-000E	30	25	20	41	46	10	41	30.5	55.5	54	0.710
KLC35-000E	35	28	23	46	55	11	46	34	63.5	58	0.810
※KLC38-000N	38	32	26	50	60	12	50	36	69.5	72	1.332

注. 予告なしに、品質・性能・改善のため寸法を変更する事があります。

Note. Dimensions might be modified due to improvement of quality and performance.

スタッドエルボ (B形)

STUD ELBOW (B)

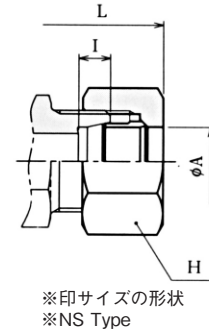
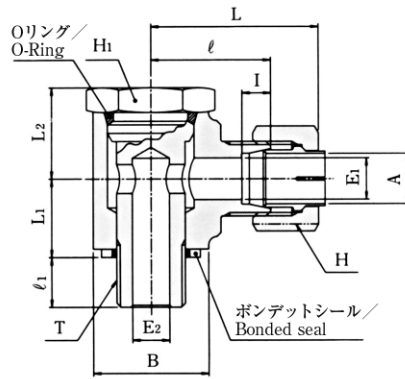

※印サイズの形状
※NS Type

単位：mm/Unit: mm

継手の呼び Part No.	適用管外径 Out. Dia. of Applied Pipe A		(G) T	B	E ₁	E ₂	六角対辺 Hex Width		I	ℓ ₁	ℓ	L ₁	L ₂	手締め(約) Fingertight Length (about) L	ボンデット シール Bonded seal K-PC-	Oリング O-ring JIS B2401 -1B	重量 Weight (kg)
	呼び径 Nominal sizes	外径 Out. Dia.					H ₁	H									
KMB06-010E	6	1/8	18	4	4	17	14	7	8	23	13	14	33.5	01	P10	0.078	
KMB08-020E	8	1/4	22	6	7	22	17	7	12	25	16	17	35.5	02	P12	0.127	
KMB10-020E	10	1/4	22	8	7	22	19	7	12	25	16	17	36.5	02	P12	0.132	
KMB12-030E	12	3/8	28	10	9	27	22	7	12	29	19	22	40.5	03	P18	0.232	
KMB15-040E	15	1/2	37	12	12	30	27	7.5	14	36	24	28	48.5	04	P22	0.484	
KMB16-040E	16	1/2	37	13	12	30	30	7.5	14	36	24	28	48.5	04	P22	0.505	
KMB18-040E	18	1/2	37	14	12	30	32	8	14	36	24	28	48.5	04	P22	0.510	
KMB20-060E	20	3/4	42	17	16	41	36	8	16	38	28	32	50.5	05	P28	0.723	
KMB22-060E	22	3/4	42	18	16	41	36	9	16	38	28	32	50.5	05	P28	0.708	
KMB25-080E	25	1	50	20	22	50	41	10	18	42	37	38	55.5	06	P36	1.182	
KMB28-080E	28	1	50	22	22	50	46	10	18	42	37	38	56	06	P36	1.210	
※KMB11-020N	1/8	10.5	1/4	22	8	7	22	19	7	12	25	16	17	36.5	02	P12	0.130
※KMB13-030N	1/4	13.8	3/8	28	11	9	27	24	7.5	12	29	19	22	41	03	P18	0.235
※KMB17-040N	3/8	17.3	1/2	37	14	12	30	32	8	14	36	24	28	48.5	04	P22	0.511
※KMB21-060N	1/2	21.7	3/4	42	18	16	41	36	9	16	38	28	32	50.5	05	P28	0.712
※KMB27-080N	3/4	27.2	1	50	22	22	50	46	10	18	42	37	38	56	06	P36	1.215

- 注. 1. 相手ボートの形状・寸法は60ページによります。
 2. OリングはJIS B 2401のI種B (NBR) を装着してあります。
 3. 使用温度-20℃~120℃
 4. 予告なしに、品質・性能・改善のため寸法を変更する事があります。

⚠注意：継手は固定して使用する継手です。
 スイベルジョイントの代替として回転させる使用方法はしないでください。

- Note. 1. Shape and dimension of mating port is shown in page 60.
 2. O-ring of JIS B 2401 (NBR) is installed.
 3. Range of working temperature: -20℃~120℃
 4. Dimensions might be modified due to improvement of quality and performance.

⚠CAUTION: Fitting is designed to be fixedly used. Never use it for rotating purpose as replacement of swivel joint.

スタッドエルボ (C形)

STUD ELBOW (C)

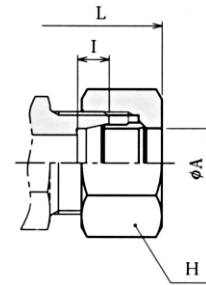
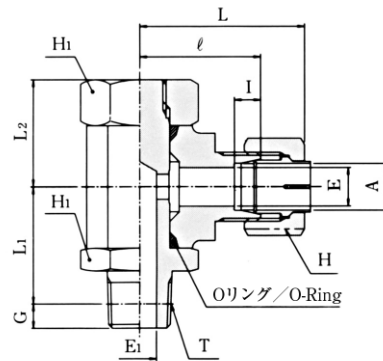

※印サイズの形状
※NS Type

単位：mm/Unit: mm

継手の呼び Part No.	適用管外径 Out. Dia. of Applied Pipe A		(R) T	E	E ₁	G	六角対辺 Hex Width		I	ℓ	L ₁	L ₂	手締め(約) Fingertight Length (about) L	Oリング O-ring JIS B2401 -1B	重量 Weight (kg)
	呼び径 Nominal sizes	外径 Out. Dia.					H ₁	H							
KMC06-010E	6		1/8	4	4	3.97	17	14	7	23	22	19	33.5	P9	0.091
KMC08-020E	8		1/4	6	7	6.01	22	17	7	29	26	23	39.5	P12.5	0.165
KMC10-020E	10		1/4	8	7	6.01	22	19	7	29	26	23	40.5	P12.5	0.170
KMC12-030E	12		3/8	10	9	6.35	27	22	7	32	31	28	44.5	P16	0.298
KMC15-040E	15		1/2	12	12	8.16	27	27	7.5	33	35	30	45.5	P18	0.360
KMC16-040E	16		1/2	13	12	8.16	27	30	7.5	33	35	30	45.5	P18	0.381
KMC18-040E	18		1/2	14	12	8.16	27	32	8	33	35	30	45.5	P18	0.386
KMC20-060E	20		3/4	17	16	9.53	36	36	8	41	44.5	38	53.5	P25	0.800
KMC22-060E	22		3/4	18	16	9.53	36	36	9	41	44.5	38	53.5	P25	0.783
KMC25-080E	25		1	20	20	10.39	46	41	10	50	53.5	44	63.5	P32	1.411
KMC28-080E	28		1	22	20	10.39	46	46	10	50	53.5	44	64	P32	1.436
※KMC11-020N	1/8	10.5	1/4	8	7	6.01	22	19	7	29	26	23	40.5	P12.5	0.169
※KMC13-030N	1/4	13.8	3/8	11	9	6.35	27	24	7.5	32	31	28	44	P16	0.312
※KMC17-040N	3/8	17.3	1/2	14	12	8.16	27	32	8	33	35	30	45.5	P18	0.387
※KMC21-060N	1/2	21.7	3/4	18	16	9.53	36	36	9	41	44.5	38	53.5	P25	0.787
※KMC27-080N	3/4	27.2	1	22	20	10.39	46	46	10	50	53.5	44	64	P32	1.439

- 注. 1. OリングはJIS B 2401の種B (NBR) を装着してあります。
 2. 使用温度-20℃~120℃
 3. 予告なしに、品質・性能・改善のため寸法を変更する事があります。

△注意：継手は固定して使用する継手です。
 スイベルジョイントの代替として回転させる使用方法はしないでください。

- Note. 1. O-ring of JIS B 2401 (NBR) is installed.
 2. Range of working temperature: -20℃~120℃
 3. Dimensions might be modified due to improvement of quality and performance.

△CAUTION: Fitting is designed to be fixedly used. Never use it for rotating purpose as replacement of swivel joint.

エルボ (めす)

FEMALE ELBOW

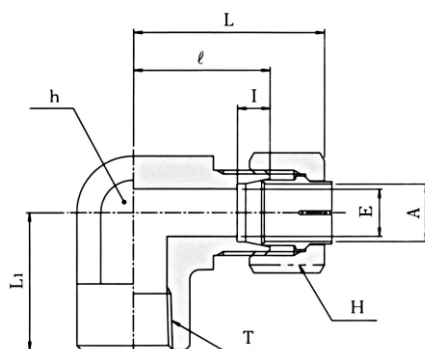

単位：mm / Unit: mm

継手の呼び Part No.	適用管外径 Out. Dia. of Applied Pipe A	(Rc) T	E	二面幅 Width across flats h	六角対辺 Hex Width H	I	ℓ	L ₁	手締め(約) Fingertight Length (about) L	重量 Weight (kg)
KLF08-020E	8	1/4	6	19	17	7	24	24	34.5	0.090
KLF10-020E	10	1/4	8	19	19	7	24	24	35.5	0.095
KLF12-020E	12	1/4	10	19	22	7	24	24	35.5	0.101
KLF12-030E	12	3/8	10	24	22	7	29	29	40.5	0.158
KLF15-030E	15	3/8	12	24	27	7.5	29	29	41.5	0.173
KLF15-040E	15	1/2	12	30	27	7.5	33	33	45.5	0.288
KLF16-040E	16	1/2	13	30	30	7.5	33	33	45.5	0.289
KLF18-040E	18	1/2	14	30	32	8	33	33	45.5	0.293
KLF20-060E	20	3/4	17	36	36	8	36	36	48.5	0.439
KLF22-060E	22	3/4	18	36	36	9	36	36	48.5	0.428
KLF25-060E	25	3/4	20	36	41	10	36	36	49.5	0.459
KLF25-080E	25	1	20	46	41	10	46	46	59.5	0.869
KLF28-080E	28	1	22	46	46	10	46	46	60	0.879
KLF30-100E	30	1 1/4	25	55	46	10	55	55	69.5	1.295
KLF35-100E	35	1 1/4	28	55	55	11	55	55	72.5	1.370

注. 予告なしに、品質・性能・改善のため寸法を変更する事があります。

Note. Dimensions might be modified due to improvement of quality and performance.

ティー

UNION TEE

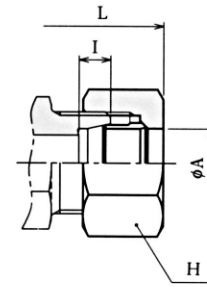
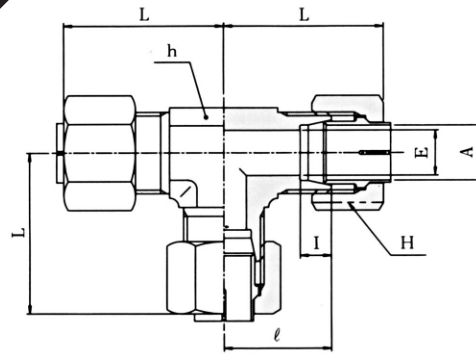

※印サイズの形状
※NS Type

単位：mm/Unit: mm

継手の呼び Part No.	適用管外径 Out. Dia. of Applied Pipe A		E	二面幅 Width across flats h	六角対辺 Hex Width H	I	ℓ	手締め(約) Fingertight Length (about) L	重量 Weight (kg)
	呼び径 Nominal sizes	外径 Out. Dia.							
※KTA04-000N		4	2.5	12	12	6	15	22.5	0.044
KTA06-000E		6	4	14	14	7	20	30.5	0.069
KTA08-000E		8	6	17	17	7	23	33.5	0.122
KTA10-000E		10	8	17	19	7	23	34.5	0.136
KTA12-000E		12	10	19	22	7	24	35.5	0.172
KTA15-000E		15	12	24	27	7.5	29	41.5	0.306
KTA16-000E		16	13	27	30	7.5	32	44.5	0.436
KTA18-000E		18	14	27	32	8	32	44.5	0.489
KTA20-000E		20	17	30	36	8	33	45.5	0.563
KTA22-000E		22	18	32	36	9	34	46.5	0.552
KTA25-000E		25	20	36	41	10	36	49.5	0.789
KTA28-000E		28	22	41	46	10	41	55	1.117
KTA30-000E		30	25	41	46	10	41	55.5	1.044
KTA35-000E		35	28	46	55	11	46	63.5	1.589
※KTA38-000N		38	32	50	60	12	50	69.5	2.052
※KTA40-000N		40	32	55	60	12	55	74.5	2.422
※KTA42-000N		42	34	55	60	12	55	74.5	2.276
※KTA50-000N		50	40	65	75	12	62	83.5	4.010
※KTA11-000N	1/8	10.5	8	17	19	7	23	34.5	0.132
※KTA13-000N	1/4	13.8	11	22	24	7.5	28	40	0.240
※KTA17-000N	3/8	17.3	14	27	32	8	32	44.5	0.452
※KTA21-000N	1/2	21.7	18	32	36	9	34	46.5	0.564
※KTA27-000N	3/4	27.2	22	41	46	10	41	55	1.127
※KTA34-000N	1	34.0	28	46	55	11	46	63.5	1.647
※KTA43-000N	1 1/4	42.7	34	60	65	12	57	77.5	3.022
※KTA48-000N	1 1/2	48.6	40	65	75	12	62	83.5	4.059

注. 予告なしに、品質・性能・改善のため寸法を変更する事があります。

Note. Dimensions might be modified due to improvement of quality and performance.

ティー片ニップル

MALE RUN TEE

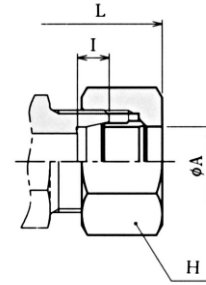
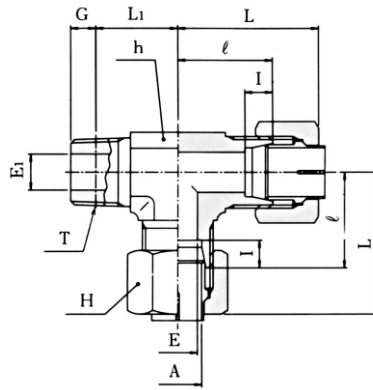

※印サイズの形状
※NS Type

単位：mm / Unit: mm

継手の呼び Part No.	適用管外径 Out. Dia. of Applied Pipe A		(R) T	E	E ₁	基準径の位置 Engagement Fingertight G	二面幅 Width across flats h	六角対辺 Hex Width H	I	ℓ	手締め(約) Fingertight Length (about) L	(約) (about) L ₁	重量 Weight (kg)
	呼び径 Nominal sizes	外径 Out. Dia.											
※KTK04-010N	4		1/8	2.5	4	3.97	12	12	6	15	22.5	13	0.037
KTK06-010E	6		1/8	4	4	3.97	14	14	7	20	30.5	14	0.062
KTK06-020E	6		1/4	4	7	6.01	17	14	7	23	33.5	17	0.087
KTK08-010E	8		1/8	6	4	3.97	17	17	7	23	33.5	16	0.098
KTK08-020E	8		1/4	6	7	6.01	17	17	7	23	33.5	18	0.102
KTK10-020E	10		1/4	8	7	6.01	17	19	7	23	34.5	19	0.114
KTK10-030E	10		3/8	8	9	6.35	19	19	7	24	35.5	19.5	0.136
KTK12-020E	12		1/4	10	7	6.01	19	22	7	24	35.5	18	0.135
KTK12-030E	12		3/8	10	9	6.35	19	22	7	24	35.5	20.5	0.143
KTK15-030E	15		3/8	12	9	6.35	24	27	7.5	29	41.5	23.5	0.255
KTK15-040E	15		1/2	12	12	8.16	24	27	7.5	29	41.5	26	0.267
KTK16-040E	16		1/2	13	12	8.16	27	30	7.5	32	44.5	27	0.368
KTK18-040E	18		1/2	14	12	8.16	27	32	8	32	44.5	30	0.387
KTK20-060E	20		3/4	17	16	9.53	30	36	8	33	45.5	30.5	0.486
KTK22-060E	22		3/4	18	16	9.53	32	36	9	34	46.5	32.5	0.496
KTK25-060E	25		3/4	20	16	9.53	36	41	10	36	49.5	33.5	0.687
KTK25-080E	25		1	20	22	10.39	36	41	10	36	49.5	35.5	0.690
KTK28-080E	28		1	22	22	10.39	41	46	10	41	55	39.5	0.986
KTK30-080E	30		1	25	22	10.39	41	46	10	41	55.5	39.5	0.929
KTK30-100E	30		1 1/4	25	31	12.70	46	46	10	46	60.5	42.5	1.140
KTK35-100E	35		1 1/4	28	31	12.70	46	55	11	46	63.5	45.5	1.347
※KTK38-120N	38		1 1/2	32	36	12.70	50	60	12	50	69.5	48.5	1.688
※KTK40-120N	40		1 1/2	32	36	12.70	55	60	12	55	74.5	49.5	2.084
※KTK50-160N	50		2	40	46	15.88	65	75	12	62	83.5	58	3.327
※KTK11-020N	1/8	10.5	1/4	8	7	6.01	17	19	7	23	34.5	19	0.110
※KTK13-030N	1/4	13.8	3/8	11	9	6.35	22	24	7.5	28	40	22.5	0.204
※KTK17-040N	3/8	17.3	1/2	14	12	8.16	27	32	8	32	44.5	30	0.389
※KTK21-060N	1/2	21.7	3/4	18	16	9.53	32	36	9	34	46.5	32.5	0.504
※KTK27-080N	3/4	27.2	1	22	22	10.39	41	46	10	41	55	39.5	0.993
※KTK34-100N	1	34.0	1 1/4	28	31	12.70	46	55	11	46	63.5	45.5	1.387
※KTK43-120N	1 1/4	42.7	1 1/2	34	36	12.70	60	65	12	57	77.5	51.5	2.561
※KTK48-160N	1 1/2	48.6	2	40	46	15.88	65	75	12	62	83.5	58	3.363

注. 予告なしに、品質・性能・改善のため寸法を変更する事があります。

Note. Dimensions might be modified due to improvement of quality and performance.

ティー中ニップル

MALE BRANCH TEE

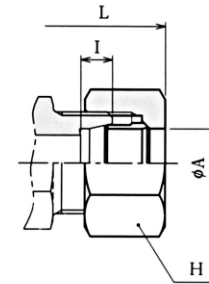
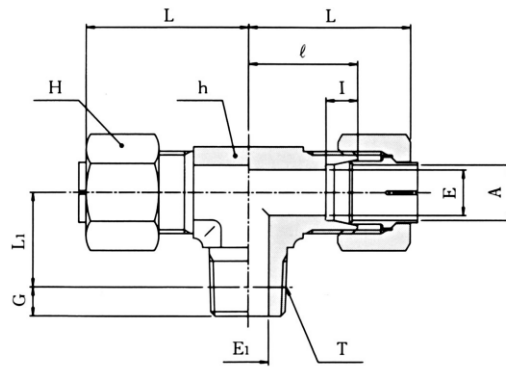

※印サイズの形状
※NS Type

単位：mm/Unit: mm

継手の呼び Part No.	適用管外径 Out. Dia. of Applied Pipe A		(R) T	E	E ₁	基準径の位置 Engagement Fingertight G	二面幅 Width across flats h	六角対辺 Hex Width H	I	ℓ	手締め(約) Fingertight Length (about) L	(約) (about) L ₁	重量 Weight (kg)
	呼び径 Nominal sizes	外径 Out. Dia.											
※KTN04-010N	4		1/8	2.5	4	3.97	12	12	6	15	22.5	13	0.039
KTN06-010E	6		1/8	4	4	3.97	14	14	7	20	30.5	14	0.062
KTN06-020E	6		1/4	4	7	6.01	17	14	7	23	33.5	17	0.087
KTN08-010E	8		1/8	6	4	3.97	17	17	7	23	33.5	16	0.098
KTN08-020E	8		1/4	6	7	6.01	17	17	7	23	33.5	18	0.102
KTN10-020E	10		1/4	8	7	6.01	17	19	7	23	34.5	19	0.114
KTN10-030E	10		3/8	8	9	6.35	19	19	7	24	35.5	19.5	0.136
KTN12-020E	12		1/4	10	7	6.01	19	22	7	24	35.5	18	0.135
KTN12-030E	12		3/8	10	9	6.35	19	22	7	24	35.5	20.5	0.143
KTN15-030E	15		3/8	12	9	6.35	24	27	7.5	29	41.5	23.5	0.256
KTN15-040E	15		1/2	12	12	8.16	24	27	7.5	29	41.5	26	0.266
KTN16-040E	16		1/2	13	12	8.16	27	30	7.5	32	44.5	27	0.368
KTN18-040E	18		1/2	14	12	8.16	27	32	8	32	44.5	30	0.388
KTN20-060E	20		3/4	17	16	9.53	30	36	8	33	45.5	30.5	0.486
KTN22-060E	22		3/4	18	16	9.53	32	36	9	34	46.5	32.5	0.497
KTN25-060E	25		3/4	20	16	9.53	36	41	10	36	49.5	33.5	0.687
KTN25-080E	25		1	20	22	10.39	36	41	10	36	49.5	35.5	0.690
KTN28-080E	28		1	22	22	10.39	41	46	10	41	55	39.5	0.986
KTN30-080E	30		1	25	22	10.39	41	46	10	41	55.5	39.5	0.929
KTN30-100E	30		1 1/4	25	31	12.70	46	46	10	46	60.5	42.5	1.140
KTN35-100E	35		1 1/4	28	31	12.70	46	55	11	46	63.5	45.5	1.374
※KTN38-120N	38		1 1/2	32	36	12.70	50	60	12	50	69.5	48.5	1.766
※KTN40-120N	40		1 1/2	32	36	12.70	55	60	12	55	74.5	49.5	2.075
※KTN50-160N	50		2	40	46	15.88	65	75	12	62	83.5	58	3.436
※KTN11-020N	1/8	10.5	1/4	8	7	6.01	17	19	7	23	34.5	19	0.111
※KTN13-030N	1/4	13.8	3/8	11	9	6.35	22	24	7.5	28	40	22.5	0.204
※KTN17-040N	3/8	17.3	1/2	14	12	8.16	27	32	8	32	44.5	30	0.386
※KTN21-060N	1/2	21.7	3/4	18	16	9.53	32	36	9	34	46.5	32.5	0.505
※KTN27-080N	3/4	27.2	1	22	22	10.39	41	46	10	41	55	39.5	0.993
※KTN34-100N	1	34.0	1 1/4	28	31	12.70	46	55	11	46	63.5	45.5	1.412
※KTN43-120N	1 1/4	42.7	1 1/2	34	36	12.70	60	65	12	57	77.5	51.5	2.586
※KTN48-160N	1 1/2	48.6	2	40	46	15.88	65	75	12	62	83.5	58	3.468

注. 予告なしに、品質・性能・改善のため寸法を変更する事があります。

Note. Dimensions might be modified due to improvement of quality and performance.

リングガスケット形ティー

O-SEAL MALE BRANCH TEE

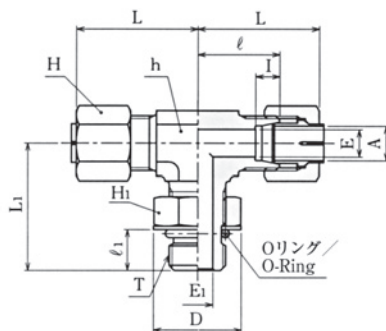

単位：mm/Unit: mm

継手の呼び Part No.	適用管 外径 Out. Dia. of Applied Pipe A	(G) T	E	E ₁	二面幅 Width across flats h	六角対辺 Hex Width		I	ℓ ₁	ℓ	L ₁	手締め(約) Fingertight Length (about) L	D	Oリング O-ring JISB2401 -1B	重量 Weight (kg)
						H ₁	H								
KTO08-020E	8	1/4	6	7	17	19	17	7	11	23	35	33.5	20	P11	0.118
KTO10-020E	10	1/4	8	7	17	19	19	7	11	23	35	34.5	20	P11	0.129
KTO10-030E	10	3/8	8	9	19	22	19	7	12	24	36	35.5	25.6	P14	0.156
KTO12-020E	12	1/4	10	6	19	19	22	7	11	24	37	35.5	20	P11	0.160
KTO12-030E	12	3/8	10	9	19	22	22	7	12	24	37	35.5	25.6	P14	0.168
KTO15-030E	15	3/8	12	9	27	22	27	7.5	12	32	49	44.5	25.6	P14	0.334
KTO15-040E	15	1/2	12	12	27	27	27	7.5	16	32	50	44.5	29	P18	0.410
KTO16-040E	16	1/2	13	12	27	27	30	7.5	16	32	50	44.5	29	P18	0.442
KTO18-030E	18	3/8	14	9	32	22	32	8	12	34	46	46.5	25.6	P14	0.485
KTO18-040E	18	1/2	14	12	32	27	32	8	16	34	46	46.5	29	P18	0.500
KTO20-060E	20	3/4	17	16	32	36	36	8	17	34	46.5	46.5	38	P24	0.592
KTO22-040E	22	1/2	18	12	32	27	36	9	16	34	46	46.5	29	P18	0.573
KTO22-060E	22	3/4	18	16	32	36	36	9	17	34	46.5	46.5	38	P24	0.522

- 注. 1. 相手ポートの形状・寸法は60ページによります。
 2. OリングはJIS B 2401の1種B (NBR) 装着してあります。(使用温度-20℃~120℃)
 3. G_{3/4}平行ねじ部のOリング溝径及び適用するOリングは、1990年改正前のJIS B 2351の寸法を採用しております。又、ポート入口径は、Oリングが破損するなどの不都合を改善するため、弊社推奨寸法のφ30.5を掲載いたしました。(60ページ) (JIS B2351に規定されるポート入口径は新規格、旧規格共φ29.8) 尚、新JIS規格品を御希望の場合は、その旨ご指定ください。
 4. 予告なしに、品質・性能・改善のため寸法を変更する事があります。

- Note. 1. Shape and dimension of mating port is shown in page 60.
 2. O-ring of JIS B 2401 (NBR) is installed. (range of working temperature: -20℃~120℃)
 3. Diameter of O-ring groove and applied O-ring on G_{3/4} straight thread is based on JIS B 2351 prior to modified in 1990. Port diameter of entrance is recommended φ30.5 to protect from damage of O-ring as shown in page 60. Port inlet diameter that is specified in JIS B2351 is φ29.8 for both new and old standard. (Please specify when require one of new Standard.)
 4. Dimensions might be modified due to improvement of quality and performance.

ねじサイズ/Thread Size	定格圧力/Rated Pressure
G _{1/8}	35MPa
G _{1/4}	〃
G _{3/8}	〃
G _{1/2}	〃
G _{3/4}	〃
G ₁	〃
G _{1 1/4}	21MPa
G _{1 1/2}	〃

KTOのOリングポート側組付要領/Assembly figure of O-ring Port

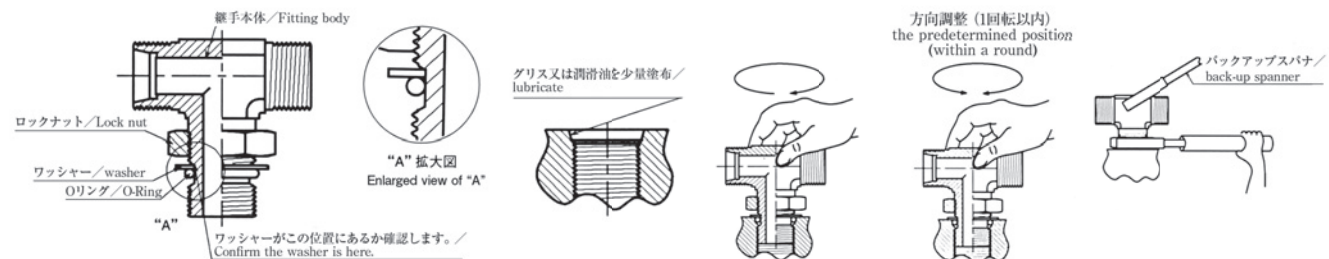

1. ロックナットの端面が継手本体のOリング溝から外れるまで移動(A方向)させます。
1. Move the locknut until coming out of O-ring groove. (to A-direction)
2. 相手ポート面にバックアップワッシャーが当たるまでねじ込みます。
2. Screw in to the mating port until the back-up washer bottoms.
3. 所定の位置まで反転(1回転以内)し方向を調整します。
3. Adjust the direction by reversing (within a round) up to the predetermined position.
4. 継手本体を固定しロックナットを締付けます。
4. Fix the fitting body with back-up spanner and tighten the locknut.

ティー片ニップル (めす)

FEMALE RUN TEE

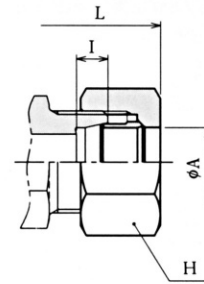
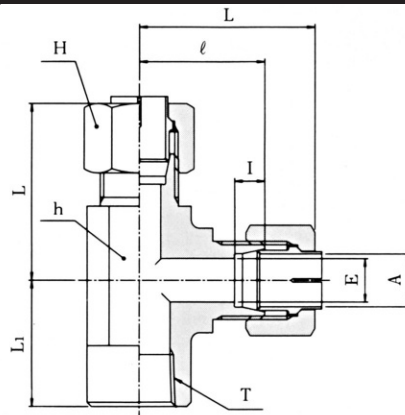

※印サイズの形状
※NS Type

単位 : mm / Unit: mm

継手の呼び Part No.	適用管外径 Out. Dia. of Applied Pipe A		(Rc) T	E	二面幅 Width across flats h	六角対辺 Hex Width H	I	ℓ	手締め(約) Fingertight Length (about) L	L ₁	重量 Weight (kg)
	呼び径 Nominal sizes	外径 Out. Dia.									
KTF08-020E	8		1/4	6	19	17	7	24	34.5	24	0.124
KTF10-020E	10		1/4	8	19	19	7	24	35.5	24	0.134
KTF12-020E	12		1/4	10	19	22	7	24	35.5	24	0.149
KTF12-030E	12		3/8	10	24	22	7	29	40.5	29	0.211
KTF15-030E	15		3/8	12	24	27	7.5	29	41.5	29	0.257
KTF15-040E	15		1/2	12	30	27	7.5	33	45.5	33	0.372
KTF16-040E	16		1/2	13	30	30	7.5	33	45.5	33	0.412
KTF18-040E	18		1/2	14	30	32	8	33	45.5	33	0.421
KTF20-060E	20		3/4	17	36	36	8	36	48.5	36	0.615
KTF22-060E	22		3/4	18	36	36	9	36	48.5	36	0.577
KTF25-060E	25		3/4	20	36	41	10	36	49.5	36	0.673
KTF25-080E	25		1	20	46	41	10	46	59.5	46	1.173
KTF28-080E	28		1	22	46	46	10	46	60	46	1.223
KTF30-080E	30		1	25	46	46	10	46	60.5	46	1.182
KTF30-100E	30		1 1/4	25	55	46	10	55	69.5	55	1.924
KTF35-100E	35		1 1/4	28	55	55	11	55	72.5	55	2.060
※KTF11-020N	1/8	10.5	1/4	8	19	19	7	24	35.5	24	0.131
※KTF13-030N	1/4	13.8	3/8	11	24	24	7.5	29	41	29	0.229
※KTF17-040N	3/8	17.3	1/2	14	30	32	8	33	45.5	33	0.424
※KTF21-060N	1/2	21.7	3/4	18	36	36	9	36	48.5	36	0.585
※KTF27-080N	3/4	27.2	1	22	46	46	10	46	60	46	1.230
※KTF34-100N	1	34.0	1 1/4	28	55	55	11	55	72.5	55	1.954

注. 予告なしに、品質・性能・改善のため寸法を変更する事があります。

Note. Dimensions might be modified due to improvement of quality and performance.

ティー中ニップル (めす)

FEMALE BRANCH TEE

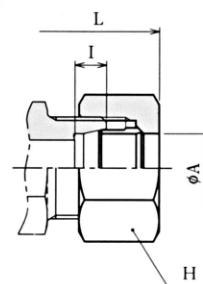
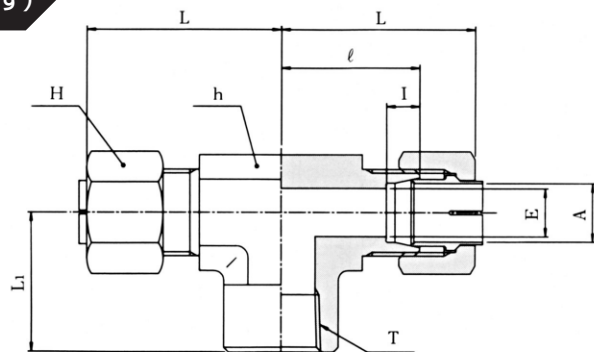

※印サイズの形状
※NS Type

単位：mm/Unit: mm

継手の呼び Part No.	適用管外径 Out. Dia. of Applied Pipe A		(Rc) T	E	二面幅 Width across flats h	六角対辺 Hex Width H	I	ℓ	手締め(約) Fingertight Length (about) L	L ₁	重量 Weight (kg)
	呼び径 Nominal sizes	外径 Out. Dia.									
KTH08-020E	8		1/4	6	19	17	7	24	34.5	24	0.127
KTH10-020E	10		1/4	8	19	19	7	24	35.5	24	0.137
KTH12-020E	12		1/4	10	19	22	7	24	35.5	24	0.150
KTH12-030E	12		3/8	10	24	22	7	29	40.5	29	0.222
KTH15-030E	15		3/8	12	24	27	7.5	29	41.5	29	0.262
KTH15-040E	15		1/2	12	30	27	7.5	33	45.5	33	0.385
KTH16-040E	16		1/2	13	30	30	7.5	33	45.5	33	0.424
KTH18-040E	18		1/2	14	30	32	8	33	45.5	33	0.422
KTH20-060E	20		3/4	17	36	36	8	36	48.5	36	0.639
KTH22-060E	22		3/4	18	36	36	9	36	48.5	36	0.608
KTH25-060E	25		3/4	20	36	41	10	36	49.5	36	0.679
KTH25-080E	25		1	20	46	41	10	46	59.5	46	1.225
KTH28-080E	28		1	22	46	46	10	46	60	46	1.270
KTH30-080E	30		1	25	46	46	10	46	60.5	46	1.213
KTH30-100E	30		1 1/4	25	55	46	10	55	69.5	55	1.857
KTH35-100E	35		1 1/4	28	55	55	11	55	72.5	55	2.010
※KTH11-020N	1/8	10.5	1/4	8	19	19	7	24	35.5	24	0.134
※KTH13-030N	1/4	13.8	3/8	11	24	24	7.5	29	41	29	0.234
※KTH17-040N	3/8	17.3	1/2	14	30	32	8	33	45.5	33	0.434
※KTH21-060N	1/2	21.7	3/4	18	36	36	9	36	48.5	36	0.616
※KTH27-080N	3/4	27.2	1	22	46	46	10	46	60	46	1.277
※KTH34-100N	1	34.0	1 1/4	28	55	55	11	55	72.5	55	2.050

注. 予告なしに、品質・性能・改善のため寸法を変更する事があります。

Note. Dimensions might be modified due to improvement of quality and performance.

方向調整片ティー

ADJUSTABLE RUN TEE

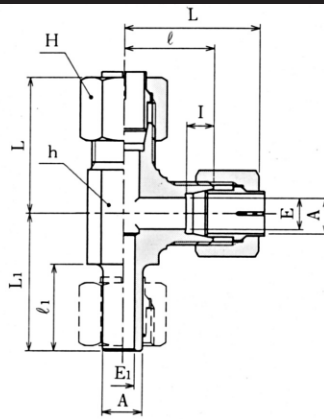

単位：mm/Unit: mm

継手の呼び Part No.	適用管外径 Out. Dia. of Applied Pipe A	E	E ₁	二面幅 Width across flats h	六角対辺 Hex Width H	I	ℓ	ℓ ₁	手締め(約) Fingertight Length (about) L	L ₁	重量 Weight (kg)
KTC10-000E	10	8	6	17	19	7	23	22	34.5	35	0.118
KTC12-000E	12	10	8	19	22	7	24	22.5	35.5	37	0.149
KTC15-000E	15	12	10	27	27	7.5	32	24.5	44.5	43	0.332
KTC16-000E	16	13	11	27	30	7.5	32	24.5	44.5	43	0.371
KTC18-000E	18	14	12	27	32	8	32	24.5	44.5	43	0.383
KTC20-000E	20	17	14	32	36	8	33	26	45.5	45	0.490
KTC22-000E	22	18	14	32	36	9	34	27	46.5	46	0.489
KTC25-000E	25	20	17	41	41	10	41	29.5	54.5	50.5	0.740

注. 予告なしに、品質・性能・改善のため寸法を変更する事があります。

Note. Dimensions might be modified due to improvement of quality and performance.

方向調整中ティー

ADJUSTABLE BRANCH TEE

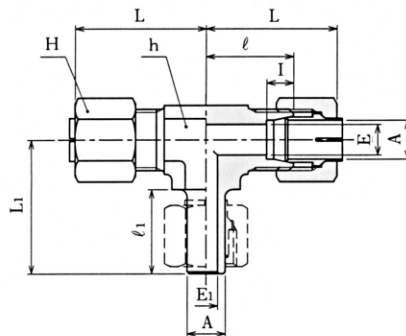

単位：mm/Unit: mm

継手の呼び Part No.	適用管外径 Out. Dia. of Applied Pipe A	E	E ₁	二面幅 Width across flats h	六角対辺 Hex Width H	I	ℓ	ℓ ₁	手締め(約) Fingertight Length (about) L	L ₁	重量 Weight (kg)
KTB10-000E	10	8	6	17	19	7	23	22	34.5	35	0.119
KTB12-000E	12	10	8	19	22	7	24	22.5	35.5	37	0.150
KTB15-000E	15	12	10	27	27	7.5	32	24.5	44.5	43	0.333
KTB16-000E	16	13	11	27	30	7.5	32	24.5	44.5	43	0.372
KTB18-000E	18	14	12	27	32	8	32	24.5	44.5	43	0.384
KTB20-000E	20	17	14	32	36	8	33	26	45.5	45	0.492
KTB22-000E	22	18	14	32	36	9	34	27	46.5	46	0.491
KTB25-000E	25	20	17	41	41	10	41	29.5	54.5	50.5	0.741

注. 予告なしに、品質・性能・改善のため寸法を変更する事があります。

Note. Dimensions might be modified due to improvement of quality and performance.

クロス

UNION CROSS

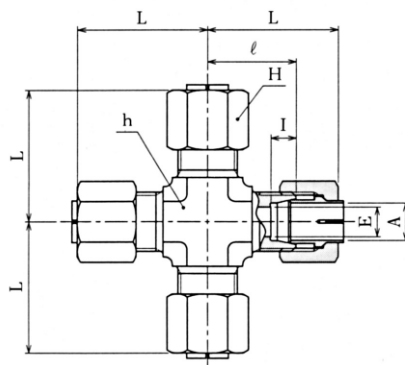

単位：mm/Unit: mm

継手の呼び Part No.	適用管外径 Out. Dia. of Applied Pipe A	E	二面幅 Width across flats h	六角対辺 Hex Width H	I	ℓ	手締め(約) Fingertight Length (about) L	重量 Weight (kg)
KXA06-000E	6	4	19	14	7	23	33.5	0.148
KXA08-000E	8	6	19	17	7	23	33.5	0.175
KXA10-000E	10	8	19	19	7	24	35.5	0.190
KXA12-000E	12	10	19	22	7	24	35.5	0.230
KXA15-000E	15	12	27	27	7.5	28	40.5	0.428

注. 予告なしに、品質・性能・改善のため寸法を変更する事があります。

Note. Dimensions might be modified due to improvement of quality and performance.

キャップ

CAP

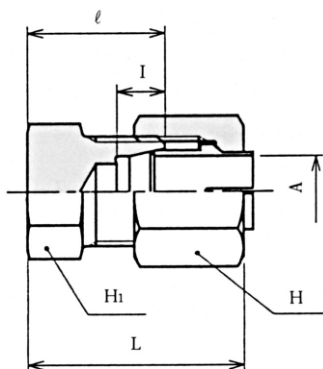

単位：mm/Unit: mm

継手の呼び Part No.	適用管外径 Out. Dia. of Applied Pipe A	六角対辺 Hex Width		I	ℓ	手締め(約) Fingertight Length (about) L	重量 Weight (kg)
		H ₁	H				
KCA06-000E	6	14	14	7	18	28.5	0.027
KCA08-000E	8	17	17	7	19	29.5	0.040
KCA10-000E	10	17	19	7	20	31.5	0.049
KCA12-000E	12	19	22	7	20	31.5	0.062
KCA15-000E	15	24	27	7.5	22	34.5	0.103
KCA16-000E	16	27	30	7.5	24	36.5	0.142
KCA18-000E	18	27	32	8	24	36.5	0.149
KCA20-000E	20	30	36	8	24	36.5	0.193
KCA22-000E	22	32	36	9	25	37.5	0.192
KCA25-000E	25	36	41	10	25	38.5	0.257
KCA28-000E	28	41	46	10	28	42	0.360
KCA30-000E	30	41	46	10	28	42.5	0.353
KCA35-000E	35	46	55	11	30	47.5	0.460

注. 予告なしに、品質・性能・改善のため寸法を変更する事があります。

Note. Dimensions might be modified due to improvement of quality and performance.

プラグ

PLUG

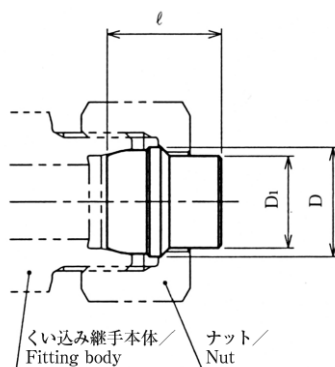

単位：mm / Unit: mm

継手の呼び Part No.	適用管外径 Out. Dia. of Applied Pipe	D ₁	D	ℓ	重量 Weight (kg)
KBA06-000E	6	7.1	9.5	19	0.006
KBA08-000E	8	9.1	11.5	19	0.009
KBA10-000E	10	11.1	13.5	19	0.013
KBA12-000E	12	13.1	15.5	19	0.019
KBA15-000E	15	16.1	19	20	0.031
KBA16-000E	16	17.1	20	20	0.033
KBA18-000E	18	19.3	22.5	20	0.044
KBA20-000E	20	21.5	25	20	0.054
KBA22-000E	22	23.5	27	20	0.065
KBA25-000E	25	26.5	30	24	0.100
KBA28-000E	28	29.5	33	24	0.125
KBA30-000E	30	31.6	35.5	24	0.143
KBA35-000E	35	36.7	40.5	30	0.257

- 注. 1. 組立要領：手締め位置より¼回転だけナットを締め込んでください。
2回目以降は手締め位置より½～⅓回転ナットを締め込んでください。
2. 予告なしに、品質・性能・改善のため寸法を変更する事があります。

- Note. 1. Assembly procedure: Tighten ¼ turn after fingertight position.
When remake after second time, tighten nut ½～⅓ turn additionally.
2. Dimensions might be modified due to improvement of quality and performance.

レジュースー

REDUCER

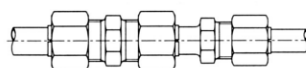
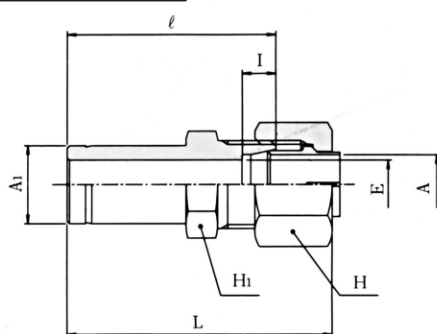

使用例
Example of Use

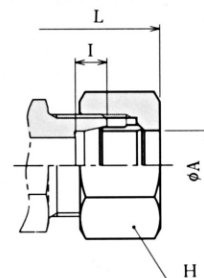

※印サイズの形状
※NS Type

単位：mm / Unit: mm

継手の呼び Part No.	対応する 継手の呼び Tube Side Nominal Size	A ₁	適用管外径 Out. Dia. of Applied Pipe A		E	六角対辺 Hex Width		I	l	手締め(約) Fingertight Length (about) L	重量 Weight (kg)
			呼び径 Nominal sizes	外径 Out. Dia.		H ₁	H				
KRE08-060E	8	8	6	6	4	14	14	7	39	49.5	0.032
KRE10-060E	10	10	6	6	4	14	14	7	40	50.5	0.033
KRE10-080E	10	10	8	8	6	17	17	7	40	50.5	0.046
KRE12-060E	12	12	6	6	4	14	14	7	41	51.5	0.036
KRE12-080E	12	12	8	8	6	17	17	7	41	51.5	0.048
KRE12-100E	12	12	10	10	8	17	19	7	41	52.5	0.054
KRE15-080E	15	15	8	8	6	17	17	7	43	53.5	0.055
KRE15-100E	15	15	10	10	8	17	19	7	43	54.5	0.061
KRE16-060E	16	16	6	6	4	17	14	7	43	53.5	0.049
KRE16-100E	16	16	10	10	8	17	19	7	43	54.5	0.071
KRE16-120E	16	16	12	12	10	19	22	7	43	54.5	0.076
KRE18-100E	18	18	10	10	8	19	19	7	44	55.5	0.087
KRE18-150E	18	18	15	15	12	24	27	7.5	45	57.5	0.123
KRE20-060E	20	20	6	6	4	22	14	7	45	55.5	0.072
KRE20-120E	20	20	12	12	10	22	22	7	45	56.5	0.092
KRE20-160E	20	20	16	16	13	27	30	7.5	47	59.5	0.159
KRE22-150E	22	22	15	15	12	24	27	7.5	48	60.5	0.145
KRE22-180E	22	22	18	18	14	27	32	8	48	60.5	0.175
KRE25-160E	25	25	16	16	13	27	30	7.5	50	62.5	0.177
KRE25-200E	25	25	20	20	17	30	36	8	52	64.5	0.231
KRE28-180E	28	28	18	18	14	30	32	8	52	64.5	0.210
KRE28-220E	28	28	22	22	18	32	36	9	52	64.5	0.244
KRE30-200E	30	30	20	20	17	32	36	8	53	65.5	0.291
KRE30-250E	30	30	25	25	20	36	41	10	54	67.5	0.322
KRE35-220E	35	35	22	22	18	36	36	9	58	70.5	0.383
KRE35-280E	35	35	28	28	22	36	46	10	60	74	0.464
KRE38-250E	38	38	25	25	20	41	41	10	61	74.5	0.424
KRE38-300E	38	38	30	30	25	41	46	10	63	77.5	0.475
※KRE13-110N	13 (1/4)	13.8	1/8	10.5	8	17	19	7	41	52.5	0.059
※KRE17-110N	17 (3/8)	17.3	1/8	10.5	8	19	19	7	44	55.5	0.070
※KRE17-130N	17 (3/8)	17.3	1/4	13.8	11	22	24	7.5	46	58	0.084
※KRE21-130N	21 (1/2)	21.7	1/4	13.8	11	24	24	7.5	48	60	0.123
※KRE21-170N	21 (1/2)	21.7	3/8	17.3	14	27	32	8	48	60.5	0.174
※KRE27-170N	27 (3/4)	27.2	3/8	17.3	14	30	32	8	52	64.5	0.221
※KRE27-210N	27 (3/4)	27.2	1/2	21.7	18	32	36	9	52	64.5	0.243
※KRE34-210N	34 (1)	34.0	1/2	21.7	18	36	36	9	58	70.5	0.317
※KRE34-270N	34 (1)	34.0	3/4	27.2	22	41	46	10	60	74	0.454

注. 予告なしに、品質・性能・改善のため寸法を変更する事があります。

Note. Dimensions might be modified due to improvement of quality and performance.

アダプタ

ADAPTER

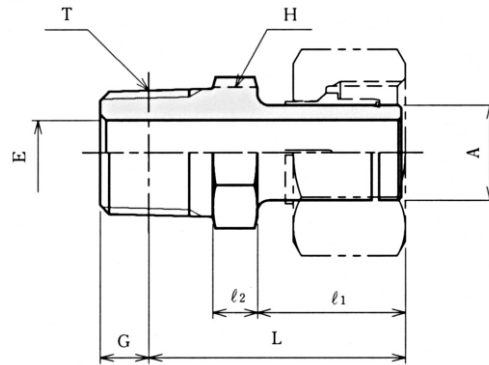

単位：mm/Unit: mm

継手の呼び Part No.	適用管外径 Out. Dia. of Applied Pipe A		(R) T	E	基準径の位置 Engagement Fingertight G	六角対辺 Hex Width H	l ₁	l ₂	(約) (about) L	重量 Weight (kg)
	呼び径 Nominal sizes	外径 Out. Dia.								
KHA06-010E	6		1/8	3	3.97	12	21	5	32	0.013
KHA08-020E	8		1/4	5	6.01	14	21	6	35	0.024
KHA10-020E	10		1/4	6	6.01	14	22	6	36	0.026
KHA10-030E	10		3/8	6	6.35	19	22	6	36.5	0.044
KHA12-020E	12		1/4	7	6.01	14	22.5	6.5	37	0.029
KHA12-030E	12		3/8	8	6.35	19	22.5	6.5	37.5	0.042
KHA15-030E	15		3/8	8	6.35	19	24.5	7.5	40.5	0.058
KHA15-040E	15		1/2	10	8.16	22	24.5	7.5	43	0.075
KHA16-030E	16		3/8	9	6.35	19	24.5	7.5	40.5	0.051
KHA16-040E	16		1/2	11	8.16	22	24.5	7.5	43	0.073
KHA18-040E	18		1/2	12	8.16	22	24.5	7.5	43	0.076
KHA20-040E	20		1/2	12	8.16	24	26	7	44	0.083
KHA20-060E	20		3/4	14	9.53	27	26	9	46.5	0.128
KHA22-060E	22		3/4	14	9.53	27	27	9	47.5	0.142
KHA25-060E	25		3/4	16	9.53	27	29.5	8.5	49.5	0.133
KHA25-080E	25		1	17	10.39	36	29.5	9.5	52.5	0.246
KHA28-080E	28		1	18	10.39	36	29.5	9.5	52.5	0.260
KHA30-080E	30		1	20	10.39	36	30.5	9.5	53.5	0.253
KHA30-100E	30		1 1/4	20	12.70	46	30.5	10.5	55	0.442
KHA35-100E	35		1 1/4	24	12.70	46	34	11	59	0.362
KHA38-120N	38		1 1/2	26	12.70	50	36	14	64.5	0.600
KHA40-120N	40		1 1/2	28	12.70	50	36	14	64	0.583
KHA50-160N	50		2	34	15.88	65	37	20	72	1.168
KHA11-020N	1/8	10.5	1/4	6	6.01	14	21	7	36	0.027
KHA13-030N	1/4	13.8	3/8	9	6.35	19	22	8	38.5	0.046
KHA17-040N	3/8	17.3	1/2	11	8.16	22	24	8	43	0.080
KHA21-060N	1/2	21.7	3/4	14	9.53	27	26	10	47.5	0.140
KHA27-080N	3/4	27.2	1	18	10.39	36	28	11	52.5	0.252
KHA34-100N	1	34.0	1 1/4	23	12.70	46	33	12	59	0.449
KHA43-120N	1 1/4	42.7	1 1/2	29	12.70	50	36	17	67	0.641
KHA48-160N	1 1/2	48.6	2	33	15.88	65	37	20	72	1.173

注. 予告なしに、品質・性能・改善のため寸法を変更する事があります。

Note. Dimensions might be modified due to improvement of quality and performance.

平行ねじアダプタ (Oリング, ボンデッドシール用)

STRAIGHT THREAD ADAPTER

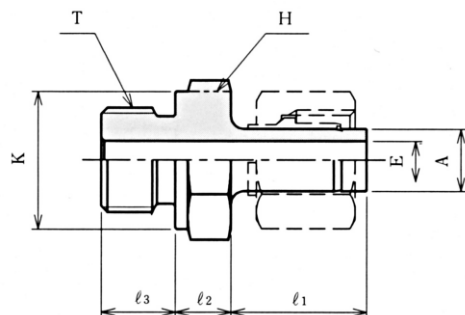

単位 : mm / Unit: mm

継手の呼び Part No.	適用管外径 Out. Dia. of Applied Pipe A		(G) T	E	六角対辺 Hex Width H	K	ℓ ₁	ℓ ₂	ℓ ₃	重量 Weight (kg)
	呼び径 Nominal sizes	外径 Out. Dia.								
KHB06-010E	6		1/8	3	14	14	21	7	8	0.016
KHB08-020E	8		1/4	5	19	19	21	8	12	0.033
KHB10-020E	10		1/4	6	19	19	22	8	12	0.035
KHB10-030E	10		3/8	6	22	22	22	9	12	0.053
KHB12-020E	12		1/4	7	19	19	22.5	8.5	12	0.078
KHB12-030E	12		3/8	8	22	22	22.5	9.5	12	0.051
KHB15-030E	15		3/8	8	22	22	24.5	9.5	12	0.064
KHB15-040E	15		1/2	10	27	27	24.5	12.5	14	0.097
KHB16-030E	16		3/8	8	22	22	24.5	9.5	12	0.069
KHB16-040E	16		1/2	11	27	27	24.5	12.5	14	0.098
KHB18-040E	18		1/2	12	27	27	24.5	12.5	14	0.097
KHB20-040E	20		1/2	12	27	27	26	13	14	0.113
KHB20-060E	20		3/4	14	36	36	26	15	16	0.192
KHB22-060E	22		3/4	14	36	36	27	15	16	0.207
KHB25-060E	25		3/4	16	36	36	29.5	14.5	16	0.212
KHB25-080E	25		1	17	41	41	29.5	16.5	18	0.304
KHB28-080E	28		1	18	41	41	29.5	16.5	18	0.317
KHB30-080E	30		1	20	41	41	30.5	19.5	18	0.337
KHB30-100E	30		1 1/4	20	50	50	30.5	19.5	20	0.537
KHB35-100E	35		1 1/4	24	50	50	34	20	20	0.539
KHB38-120N	38		1 1/2	26	55	55	36	21	21	0.694
KHB40-120N	40		1 1/2	28	55	55	36	21	21	0.676
KHB50-160N	50		2	34	75	75	37	28	24	1.486
KHB11-020N	1/8	10.5	1/4	6	19	19	21	9	12	0.037
KHB13-030N	1/4	13.8	3/8	9	22	22	22	10	12	0.053
KHB17-040N	3/8	17.3	1/2	11	27	27	24	13	14	0.101
KHB21-060N	1/2	21.7	3/4	14	36	36	26	16	16	0.205
KHB27-080N	3/4	27.2	1	18	41	41	28	18	18	0.310
KHB34-100N	1	34.0	1 1/4	23	50	50	33	21	20	0.542
KHB43-120N	1 1/4	42.7	1 1/2	29	55	55	36	23	21	0.729
KHB48-160N	1 1/2	48.6	2	33	75	75	37	28	24	1.492

- 注. 1. 対応するガスケットはOリング、ボンデッドシールが使用できます。(使用温度-20℃~120℃)
 2. 相手ポートの形状・寸法は60ページによります。
 3. 予告なしに、品質・性能・改善のため寸法を変更する事があります。

- Note. 1. O-ring and bonded-seal can be used as corresponding gasket. (range of working temperature: -20℃~120℃)
 2. Shape and dimension of mating port is shown in page 60.
 3. Dimensions might be modified due to improvement of quality and performance.

平行ねじアダプタ (Oリングシール用)

O-Ring Seal Straight Thread Adapter

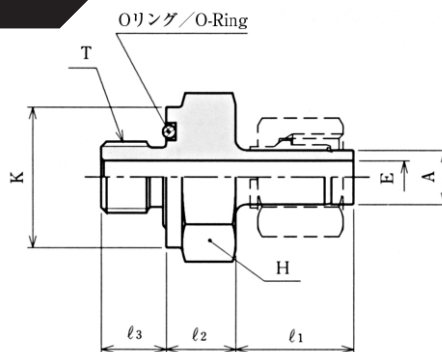

単位 : mm / Unit: mm

継手の呼び Part No.	適用管外径 Out. Dia. of Applied Pipe A	(G) T	E	六角対辺 Hex Width H	K	l ₁	l ₂	l ₃	Oリング O-ring JISB2401 -1B	重量 Weight (kg)
KH006-010E	6	1/8	3	22	22	21	10	8	P12.5	0.038
KH006-020E	6	1/4	3	27	26	21	13	12	P16	0.075
KH008-010E	8	1/8	3	22	22	21	10	8	P12.5	0.042
KH008-020E	8	1/4	5	27	26	21	13	12	P16	0.074
KH010-020E	10	1/4	6	27	26	22	13	12	P16	0.076
KH010-030E	10	3/8	6	30	30	22	13	12	P20	0.099
KH012-020E	12	1/4	6	27	26	22.5	13	12	P16	0.078
KH012-030E	12	3/8	8	30	30	22.5	13	12	P20	0.097
KH015-030E	15	1/4	8	30	30	24.5	13	12	P20	0.111
KH015-040E	15	3/8	10	36	36	24.5	16	14	G25	0.172
KH016-030E	16	3/8	8	30	30	24.5	13	12	P20	0.137
KH016-040E	16	1/2	11	36	36	24.5	16	14	G25	0.171
KH018-040E	18	1/2	12	36	36	24.5	16	14	G25	0.172
KH020-040E	20	1/2	12	36	36	26	16	14	G25	0.186
KH020-060E	20	3/4	14	41	41	26	18	16	G30	0.256
KH022-040E	22	1/2	12	36	36	27	16	14	G25	0.122
KH022-060E	22	3/4	14	41	41	27	18	16	G30	0.270
KH025-060E	25	3/4	16	41	41	29.5	18	16	G30	0.278
KH025-080E	25	1	17	50	50	29.5	21	18	P38	0.455
KH028-080E	28	1	18	50	50	29.5	21	18	P38	0.465
KH030-080E	30	1	20	50	50	30.5	21	18	P38	0.461
KH030-100E	30	1-1/4	20	65	64	30.5	24	20	P48	0.875
KH035-100E	35	1-1/4	24	65	64	34	24	20	P48	0.814

- 注. 1. OリングはJIS B 2401の1種B (NBR) を装着してあります。
(使用温度-20℃~120℃)
2. 予告なしに、品質・性能・改善のため寸法を変更する事があります。

- Note. 1. O-ring of JIS B 2401 (NBR) is installed. (range of working temperature: -20℃~120℃)
2. Dimensions might be modified due to improvement of quality and performance.

平行ねじアダプタ (銅ガスケット用)

Straight Thread Adapter (For Copper Gasket)

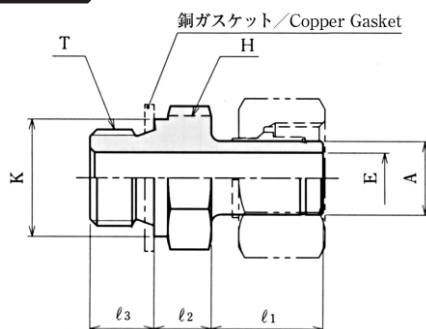

単位：mm / Unit: mm

継手の呼び Part No.	適用管外径 Out. Dia. of Applied Pipe A		(G) T	E	六角対辺 Hex Width H	K	ℓ ₁	ℓ ₂	ℓ ₃	重量 Weight (kg)
	呼び径 Nominal sizes	外径 Out. Dia.								
KHC06-010E	6		1/8	3	14	14	21	7	8	0.016
KHC08-020E	8		1/4	5	19	18	21	8	12	0.033
KHC10-020E	10		1/4	6	19	18	22	8	12	0.035
KHC10-030E	10		3/8	6	22	21.5	22	9	12	0.053
KHC12-020E	12		1/4	7	19	18	22.5	8.5	12	0.038
KHC12-030E	12		3/8	8	22	21.5	22.5	9.5	12	0.052
KHC15-030E	15		3/8	8	22	21.5	24.5	9.5	12	0.065
KHC15-040E	15		1/2	10	27	25.5	24.5	12.5	14	0.096
KHC16-040E	16		1/2	11	27	25.5	24.5	12.5	14	0.094
KHC18-040E	18		1/2	12	27	25.5	24.5	12.5	14	0.097
KHC20-060E	20		3/4	14	32	31.5	26	15	16	0.163
KHC22-060E	22		3/4	14	32	31.5	27	15	16	0.178
KHC25-060E	25		3/4	16	32	31.5	29.5	14.5	16	0.184
KHC25-080E	25		1	17	41	38	29.5	16.5	18	0.302
KHC28-080E	28		1	18	41	38	29.5	16.5	18	0.316
KHC30-080E	30		1	20	41	38	30.5	19.5	18	0.336
KHC30-100E	30		1 1/4	20	50	48.5	30.5	19.5	20	0.537
KHC35-100E	35		1 1/4	24	50	48.5	34	20	20	0.533
KHC38-120N	38		1 1/2	26	55	53.5	36	21	21	0.694
KHC40-120N	40		1 1/2	28	55	53.5	36	21	21	0.676
KHC50-160N	50		2	34	70	66	37	28	24	1.164
KHC11-020N	1/8	10.5	1/4	6	19	18	21	9	12	0.037
KHC13-030N	1/4	13.8	3/8	9	22	21.5	22	10	12	0.054
KHC17-040N	3/8	17.3	1/2	11	27	25.5	24	13	14	0.101
KHC21-060N	1/2	21.7	3/4	14	32	31.5	26	16	16	0.176
KHC27-080N	3/4	27.2	1	18	41	38	28	18	18	0.308
KHC34-100N	1	34.0	1 1/4	23	50	48.5	33	21	20	0.543
KHC43-120N	1 1/4	42.7	1 1/2	29	55	53.5	36	23	21	0.729
KHC48-160N	1 1/2	48.6	2	33	70	66	37	28	24	1.169

- 注. 1. 相手ポートの形状・寸法は60ページによります。
 2. ガスケットは標準付属いたしませんので必要の場合はその旨ご指定ください。
 3. 予告なしに、品質・性能・改善のため寸法を変更する事があります。

- Note. 1. Shape and dimension of mating port is shown in page 60.
 2. The gasket is not included in standard.
 3. Dimensions might be modified due to improvement of quality and performance.

エア抜きバルブ

AIR-PURGE VALVE

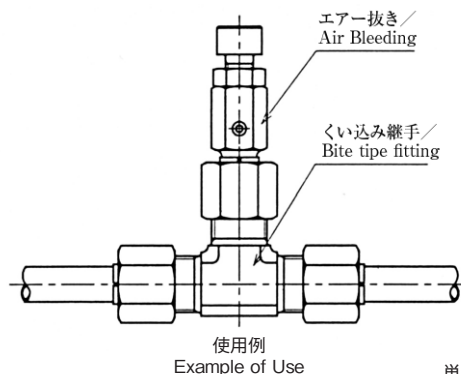
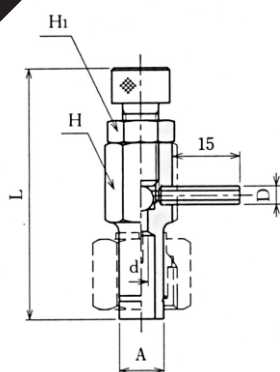

単位 : mm / Unit: mm

継手の呼び Part No.	A	D	d	六角対辺 Hex Width		L	鋼球 Steel Ball SUJ 2	重量 Weight (kg)
				H ₁	H			
KAP06-000E	6	4	3	13	14	56	7/32	0.038
KAP08-000E	8	4	3	13	14	56	7/32	0.041
KAP10-000E	10	4	3	13	14	57	7/32	0.044
KAP12-000E	12	4	3	13	14	58	7/32	0.047
KAP15-000E	15	6	4	19	27	74	5/16	0.180
KAP16-000E	16	6	4	19	27	74	5/16	0.175
KAP18-000E	18	6	4	19	27	74	5/16	0.183
KAP20-000E	20	6	4	19	27	75	5/16	0.186
KAP22-000E	22	6	4	19	27	76	5/16	0.192
KAP25-000E	25	6	4	19	27	78	5/16	0.212
KAP28-000E	28	6	4	19	30	78	5/16	0.257
KAP11-000N	10.5	4	3	13	14	57	7/32	0.046
KAP13-000N	13.8	6	4	19	27	72	5/16	0.174
KAP17-000N	17.3	6	4	19	27	74	5/16	0.188
KAP21-000N	21.7	6	4	19	27	76	5/16	0.206
KAP27-000N	27.2	6	4	19	30	79	5/16	0.266

- 注. 1. 定格圧力は3ページによります。
2. 予告なしに、品質・性能・改善のため寸法を変更する事があります。

- Note. 1. Rated pressure is shown in page 3.
2. Dimensions might be modified due to improvement of quality and performance.

ねじ込み形 エア抜きバルブ

AIR-PURGE VALVE

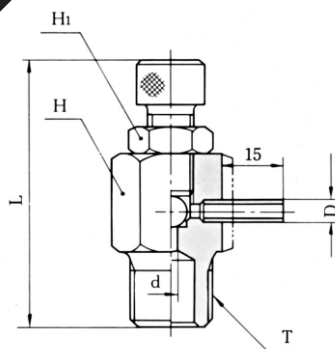

単位 : mm / Unit: mm

継手の呼び Part No.	(R) T	D	d	六角対辺 Hex Width		L	鋼球 Steel Ball SUJ 2	重量 Weight (kg)
				H ₁	H			
SAP01-000J	1/8	4	3	13	14	51	7/32	0.056
SAP02-000J	1/4	4	3	13	14	53	7/32	0.056
SAP03-000J	3/8	6	4	19	27	66	5/16	0.200
SAP04-000J	1/2	6	4	19	27	69	5/16	0.220

⚠警告 : KAP及びSAPのドレン吹き出しの方向を、人や火気に向けた状態でバルブを開放にしないでください。

⚠CAUTION: Be careful not to direct blow-out hole of KAP and SAP against humans or fire.

注. 定格圧力 : 21MPa

Note. Rated pressure: 21MPa

ホース接続ユニオン

Male Seat Hose Connection Union

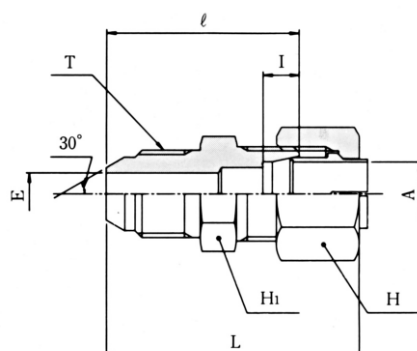

単位：mm/Unit: mm

継手の呼び Part No.	適用管外径 Out. Dia. of Applied Pipe A	(G) T	E	六角対辺 Hex Width		I	ℓ	手締め(約) Fingertight Length (about) L	重量 Weight (kg)
				H ₁	H				
KUC08-020E	8	1/4	5.5	17	17	7	35	45.5	0.047
KUC08-030E	8	3/8	6	19	17	7	37	47.5	0.062
KUC10-020E	10	1/4	5.5	17	19	7	35	46.5	0.053
KUC10-030E	10	3/8	8	19	19	7	37	48.5	0.064
KUC10-040E	10	1/2	8	22	19	7	40	51.5	0.091
KUC12-020E	12	1/4	5.5	19	22	7	35	46.5	0.064
KUC12-030E	12	3/8	8	19	22	7	37	48.5	0.070
KUC12-040E	12	1/2	10	22	22	7	40	51.5	0.094
KUC15-030E	15	3/8	8	24	27	7.5	40	52.5	0.113
KUC15-040E	15	1/2	11	24	27	7.5	42	54.5	0.121
KUC16-030E	16	3/8	8	27	30	7.5	40	52.5	0.144
KUC16-040E	16	1/2	11	27	30	7.5	42	54.5	0.152
KUC18-040E	18	1/2	11	27	32	8	42	54.5	0.157
KUC20-060E	20	3/4	16	30	36	8	46	58.5	0.223
KUC22-040E	22	1/2	11	32	36	9	44	56.5	0.197
KUC22-060E	22	3/4	16	32	36	9	46	58.5	0.213
KUC25-060E	25	3/4	16	36	41	10	47	60.5	0.286
KUC25-080E	25	1	20	36	41	10	49	62.5	0.314
KUC28-060E	28	3/4	16	41	46	10	49	63	0.369
KUC28-080E	28	1	21.5	41	46	10	51	65	0.383
KUC30-060E	30	3/4	16	41	46	10	49	63.5	0.357
KUC30-080E	30	1	21.5	41	46	10	51	65.5	0.373
KUC35-100E	35	1 1/4	28	46	55	11	56	73.5	0.565

注. 予告なしに、品質・性能・改善のため寸法を変更する事があります。

Note. Dimensions might be modified due to improvement of quality and performance.

ホース接続ユニオン (めす)

Female Seat Hose Connection Union

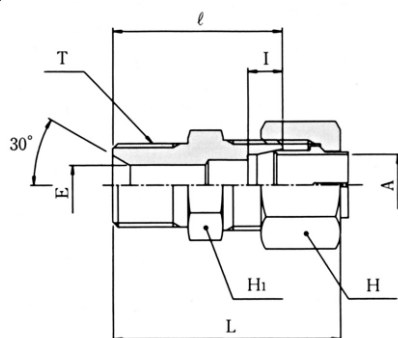

単位：mm/Unit: mm

継手の呼び Part No.	適用管外径 Out. Dia. of Applied Pipe A	(G) T	E	六角対辺 Hex Width		I	ℓ	手締め(約) Fingertight Length (about) L	重量 Weight (kg)
				H ₁	H				
KUD08-020E	8	1/4	5.5	17	17	7	33	43.5	0.046
KUD08-030E	8	3/8	6	19	17	7	34	44.5	0.055
KUD10-020E	10	1/4	5.5	17	19	7	33	44.5	0.053
KUD10-030E	10	3/8	8	19	19	7	34	45.5	0.060
KUD10-040E	10	1/2	8	22	19	7	38	49.5	0.081
KUD12-020E	12	1/4	5.5	19	22	7	33	44.5	0.064
KUD12-030E	12	3/8	8	19	22	7	34	45.5	0.069
KUD12-040E	12	1/2	10	22	22	7	38	49.5	0.088
KUD15-030E	15	3/8	8	24	27	7.5	37	49.5	0.111
KUD15-040E	15	1/2	11	24	27	7.5	40	52.5	0.121
KUD16-030E	16	3/8	8	27	30	7.5	37	49.5	0.141
KUD16-040E	16	1/2	11	27	30	7.5	40	52.5	0.152
KUD18-040E	18	1/2	11	27	32	8	40	52.5	0.155
KUD20-060E	20	3/4	16	30	36	8	43	55.5	0.219
KUD22-040E	22	1/2	11	32	36	9	42	54.5	0.200
KUD22-060E	22	3/4	16	32	36	9	43	55.5	0.219
KUD25-060E	25	3/4	16	36	41	10	44	57.5	0.280
KUD25-080E	25	1	20	36	41	10	46	59.5	0.305
KUD28-060E	28	3/4	16	41	46	10	46	60	0.361
KUD28-080E	28	1	21.5	41	46	10	48	62	0.386
KUD30-060E	30	3/4	16	41	46	10	46	60.5	0.353
KUD30-080E	30	1	21.5	41	46	10	48	62.5	0.374
KUD35-100E	35	1 1/4	28	46	55	11	55	72.5	0.569

注. 予告なしに、品質・性能・改善のため寸法を変更する事があります。

Note. Dimensions might be modified due to improvement of quality and performance.

ホース接続隔壁ユニオン

Male Seat Hose Connection Bulkhead Union

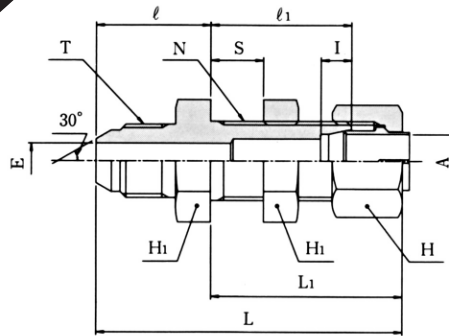

単位：mm / Unit: mm

継手の呼び Part No.	適用管 外径 Out. Dia. of Applied Pipe A	(G) T	E	六角対辺 Hex Width		I	l ₁	l	手締め(約) Fingertight Length (about)		N	最大 Max S	重量 Weight (kg)
				H ₁	H				L ₁	L			
KUE08-020E	8	1/4	6	19	17	7	32	23	42.5	65.5	M14×1.5	13	0.075
KUE08-030E	8	3/8	6	19	17	7	32	25	42.5	67.5	M14×1.5	13	0.086
KUE10-020E	10	1/4	6	22	19	7	32	24	43.5	67.5	M16×1.5	13	0.103
KUE10-030E	10	3/8	8	22	19	7	32	26	43.5	69.5	M16×1.5	13	0.108
KUE10-040E	10	1/2	8	22	19	7	32	28	43.5	71.5	M16×1.5	13	0.126
KUE12-020E	12	1/4	6	24	22	7	32	24	43.5	67.5	M18×1.5	13	0.122
KUE12-030E	12	3/8	9	24	22	7	32	26	43.5	69.5	M18×1.5	13	0.127
KUE12-040E	12	1/2	10	24	22	7	32	28	43.5	71.5	M18×1.5	13	0.139
KUE15-030E	15	3/8	9	27	27	7.5	37	26	49.5	75.5	M22×1.5	15	0.180
KUE15-040E	15	1/2	12	27	27	7.5	37	28	49.5	77.5	M22×1.5	15	0.188
KUE16-030E	16	3/8	9	30	30	7.5	37	28	49.5	77.5	M24×1.5	15	0.252
KUE16-040E	16	1/2	12	30	30	7.5	37	30	49.5	79.5	M24×1.5	15	0.254
KUE18-040E	18	1/2	12	32	32	8	39	30	51.5	81.5	M26×1.5	15	0.289
KUE20-060E	20	3/4	16	36	36	8	39	32	51.5	83.5	M28×1.5	15	0.329
KUE22-040E	22	1/2	12	36	36	9	39	31	51.5	82.5	M30×1.5	15	0.478
KUE22-060E	22	3/4	16	36	36	9	39	33	51.5	84.5	M30×1.5	15	0.368
KUE25-060E	25	3/4	16	41	41	10	39	33	52.5	85.5	M35×1.5	15	0.478
KUE25-080E	25	1	20	41	41	10	39	35	52.5	87.5	M35×1.5	15	0.507
KUE28-060E	28	3/4	16	46	46	10	41	34	55	89	M38×1.5	15	0.650
KUE28-080E	28	1	22	46	46	10	41	36	55	91	M38×1.5	15	0.635
KUE30-060E	30	3/4	16	46	46	10	41	34	55.5	89.5	M40×1.5	15	0.606
KUE30-080E	30	1	22	46	46	10	41	36	55.5	91.5	M40×1.5	15	0.627
KUE35-100E	35	1 1/4	28	50	55	11	43	42	60.5	102.5	M45×1.5	15	0.689

△注意：この形式の継手は障壁貫通を目的としたもので、強振動の発生する個所、或いは接続ホースの圧力変動が大きい個所では配管クランプ等、振動対策（継手に掛かる発生応力を軽減するため）が必要です。

注. 予告なしに、品質・性能・改善のため寸法を変更する事があります。

△CAUTION: This type of fitting is designed to be used for wall penetration. When used in the place of strong vibration and / or pressure fluctuation, proper vibration measures such as fixing the piping by clamp are required.

Note. Dimensions might be modified due to improvement of quality and performance.

ホース接続 隔壁ユニオン (めす)

Female Seat Hose Connection Bulkhead Union

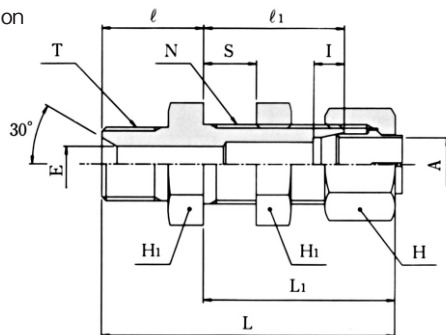

単位：mm/Unit: mm

継手の呼び Part No.	適用管 外径 Out. Dia. of Applied Pipe A	(G) T	E	六角対辺 Hex Width		I	ℓ_1	ℓ	手締め(約) Fingertight Length (about)		N	最大 Max S	重量 Weight (kg)
				H ₁	H				L ₁	L			
KUF08-020E	8	1/4	5.5	19	17	7	32	21	42.5	63.5	M14×1.5	13	0.074
KUF08-030E	8	3/8	6	19	17	7	32	22	42.5	64.5	M14×1.5	13	0.080
KUF10-020E	10	1/4	5.5	22	19	7	32	22	43.5	65.5	M16×1.5	13	0.101
KUF10-030E	10	3/8	8	22	19	7	32	23	43.5	66.5	M16×1.5	13	0.104
KUF10-040E	10	1/2	8	22	19	7	32	26	43.5	69.5	M16×1.5	13	0.116
KUF12-020E	12	1/4	5.5	24	22	7	32	22	43.5	65.5	M18×1.5	13	0.121
KUF12-030E	12	3/8	8	24	22	7	32	23	43.5	66.5	M18×1.5	13	0.125
KUF12-040E	12	1/2	10	24	22	7	32	26	43.5	69.5	M18×1.5	13	0.134
KUF15-030E	15	3/8	8	27	27	7.5	37	23	49.5	72.5	M22×1.5	15	0.181
KUF15-040E	15	1/2	11	27	27	7.5	37	26	49.5	75.5	M22×1.5	15	0.188
KUF16-030E	16	3/8	8	30	30	7.5	37	25	49.5	74.5	M24×1.5	15	0.250
KUF16-040E	16	1/2	11	30	30	7.5	37	28	49.5	77.5	M24×1.5	15	0.254
KUF18-040E	18	1/2	11	32	32	8	39	28	51.5	79.5	M26×1.5	15	0.289
KUF20-060E	20	3/4	16	36	36	8	39	29	51.5	80.5	M28×1.5	15	0.324
KUF22-040E	22	1/2	11	36	36	9	39	29	51.5	80.5	M30×1.5	15	0.346
KUF22-060E	22	3/4	16	36	36	9	39	30	51.5	81.5	M30×1.5	15	0.355
KUF25-060E	25	3/4	16	41	41	10	39	30	52.5	82.5	M35×1.5	15	0.489
KUF25-080E	25	1	20	41	41	10	39	32	52.5	84.5	M35×1.5	15	0.497
KUF28-060E	28	3/4	16	46	46	10	41	31	55	86	M38×1.5	15	0.624
KUF28-080E	28	1	21.5	46	46	10	41	33	55	88	M38×1.5	15	0.637
KUF30-060E	30	3/4	16	46	46	10	41	31	55.5	86.5	M40×1.5	15	0.629
KUF30-080E	30	1	21.5	46	46	10	41	33	55.5	88.5	M40×1.5	15	0.629
KUF35-100E	35	1 1/4	28	50	55	11	43	41	60.5	121.5	M45×1.5	15	0.693

△注意：この形式の継手は障壁貫通を目的としたもので、強振動の発生する箇所、或いは接続ホースの圧力変動が大きい箇所では配管クランプ等、振動対策（継手に掛かる発生応力を軽減するため）が必要です。

注. 予告なしに、品質・性能・改善のため寸法を変更する事があります。

△CAUTION: This type of fitting is designed to be used for wall penetration. When used in the place of strong vibration and / or pressure fluctuation, proper vibration measures such as fixing the piping by clamp are required.

Note. Dimensions might be modified due to improvement of quality and performance.

ホース接続 ユニオン エルボ

Male Seat Hose Connection Union Elbow

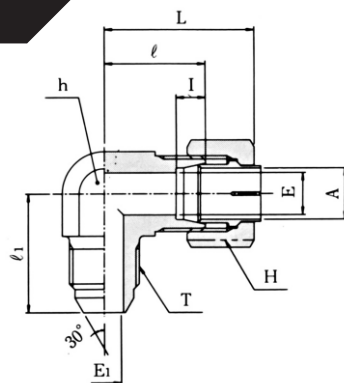

単位：mm/Unit: mm

継手の呼び Part No.	適用管外径 Out. Dia. of Applied Pipe A	(G) T	E	E ₁	二面幅 Width across flats h	六角対辺 Hex Width H	I	l ₁	l	手締め(約) Fingertight Length (about) L	重量 Weight (kg)
KLD08-020E	8	1/4	6	5.5	17	17	7	25	23	33.5	0.069
KLD08-030E	8	3/8	6	8	19	17	7	28	24	34.5	0.085
KLD10-020E	10	1/4	8	5.5	19	19	7	28	24	35.5	0.091
KLD10-030E	10	3/8	8	8	19	19	7	28	24	35.5	0.090
KLD10-040E	10	1/2	8	11	24	19	7	34	29	40.5	0.149
KLD12-020E	12	1/4	10	5.5	19	22	7	28	24	35.5	0.099
KLD12-030E	12	3/8	10	8	19	22	7	28	24	35.5	0.098
KLD12-040E	12	1/2	10	11	24	22	7	34	29	40.5	0.154
KLD15-030E	15	3/8	12	8	24	27	7.5	33	29	41.5	0.168
KLD15-040E	15	1/2	12	11	24	27	7.5	34	29	41.5	0.174
KLD16-030E	16	3/8	13	8	27	30	7.5	36	32	44.5	0.253
KLD16-040E	16	1/2	13	11	27	30	7.5	38	32	44.5	0.257
KLD18-040E	18	1/2	14	11	27	32	8	38	32	44.5	0.256
KLD20-060E	20	3/4	17	16	30	36	8	41	33	45.5	0.319
KLD22-040E	22	1/2	18	11	32	36	9	40	34	46.5	0.335
KLD22-060E	22	3/4	18	16	32	36	9	42	34	46.5	0.343
KLD25-060E	25	3/4	20	16	36	41	10	44	36	49.5	0.468
KLD25-080E	25	1	20	21.5	36	41	10	46	36	49.5	0.502
KLD28-060E	28	3/4	22	16	41	46	10	47	41	55	0.725
KLD28-080E	28	1	22	21.5	41	46	10	49	41	55	0.720
KLD30-060E	30	3/4	25	16	41	46	10	47	41	55.5	0.692
KLD30-080E	30	1	25	21.5	41	46	10	49	41	55.5	0.686
KLD35-100E	35	1 1/4	28	28	46	55	11	58	46	63.5	1.208

注. 予告なしに、品質・性能・改善のため寸法を変更する事があります。

Note. Dimensions might be modified due to improvement of quality and performance.

ホース接続 ユニオン エルボ (めす)

Female Seat Hose Connection Union Elbow

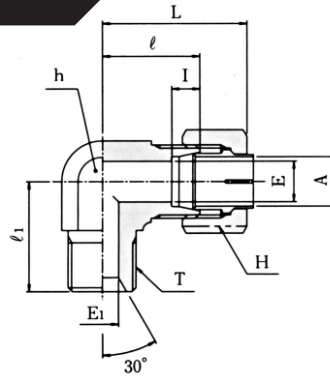

単位 : mm / Unit: mm

継手の呼び Part No.	適用管外径 Out. Dia. of Applied Pipe A	(G) T	E	E ₁	二面幅 Width across flats h	六角対辺 Hex Width H	I	l ₁	l	手締め(約) Fingertight Length (about) L	重量 Weight (kg)
KLE08-020E	8	1/4	6	5.5	17	17	7	25	23	33.5	0.071
KLE08-030E	8	3/8	6	8	19	17	7	27	24	34.5	0.088
KLE10-020E	10	1/4	8	5.5	19	19	7	26	24	35.5	0.091
KLE10-030E	10	3/8	8	8	19	19	7	27	24	35.5	0.093
KLE10-040E	10	1/2	8	11	24	19	7	33	29	40.5	0.152
KLE12-020E	12	1/4	10	5.5	19	22	7	26	24	35.5	0.096
KLE12-030E	12	3/8	10	8	19	22	7	27	24	35.5	0.102
KLE12-040E	12	1/2	10	11	24	22	7	33	29	40.5	0.157
KLE15-030E	15	3/8	12	8	24	27	7.5	30	29	41.5	0.170
KLE15-040E	15	1/2	12	11	24	27	7.5	33	29	41.5	0.177
KLE16-030E	16	3/8	13	8	27	30	7.5	33	32	44.5	0.247
KLE16-040E	16	1/2	13	11	27	30	7.5	36	32	44.5	0.258
KLE18-040E	18	1/2	14	11	27	32	8	36	32	44.5	0.256
KLE20-060E	20	3/4	17	16	30	36	8	38	33	45.5	0.326
KLE22-040E	22	1/2	18	11	32	36	9	38	34	46.5	0.335
KLE22-060E	22	3/4	18	16	32	36	9	39	34	46.5	0.339
KLE25-060E	25	3/4	20	16	36	41	10	41	36	49.5	0.469
KLE25-080E	25	1	20	21.5	36	41	10	43	36	49.5	0.498
KLE28-060E	28	3/4	22	16	41	46	10	44	41	55	0.706
KLE28-080E	28	1	22	21.5	41	46	10	46	41	55	0.722
KLE30-060E	30	3/4	25	16	41	46	10	44	41	55.5	0.673
KLE30-080E	30	1	25	21.5	41	46	10	46	41	55.5	0.689
KLE35-100E	35	1 1/4	28	28	46	55	11	57	46	63.5	1.199

注. 予告なしに、品質・性能・改善のため寸法を変更する事があります。

Note. Dimensions might be modified due to improvement of quality and performance.

ホース接続 隔壁ユニオン エルボ

Male Seat Hose Connection Bulkhead Elbow

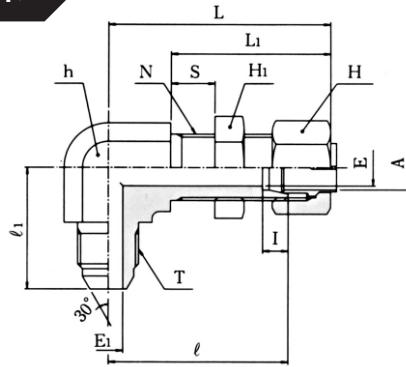

単位：mm/Unit: mm

継手の呼び Part No.	適用管 外径 Out. Dia. of Applied Pipe A	(G) T	E	E ₁	二面幅 Width across flats h	六角対辺 Hex Width H		I	l ₁	l	手締め(約) Fingertight Length (about)		N	最大 Max S	重量 Weight (kg)
						H ₁	H				L ₁	L			
KLH08-020E	8	1/4	6	5.5	19	19	17	7	28	46	42.5	56.5	M14×1.5	13	0.113
KLH08-030E	8	3/8	6	8	19	19	17	7	30	46	42.5	56.5	M14×1.5	13	0.115
KLH10-020E	10	1/4	8	5.5	22	22	19	7	30	48	43.5	59.5	M16×1.5	13	0.134
KLH10-030E	10	3/8	8	8	22	22	19	7	32	48	43.5	59.5	M16×1.5	13	0.158
KLH10-040E	10	1/2	8	11	24	22	19	7	35	49	43.5	60.5	M16×1.5	13	0.187
KLH12-020E	12	1/4	10	5.5	24	24	22	7	31	49	43.5	60.5	M18×1.5	13	0.191
KLH12-030E	12	3/8	10	8	24	24	22	7	33	49	43.5	60.5	M18×1.5	13	0.193
KLH12-040E	12	1/2	10	11	24	24	22	7	35	49	43.5	60.5	M18×1.5	13	0.198
KLH15-030E	15	3/8	12	8	27	27	27	7.5	36	57	49.5	69.5	M22×1.5	15	0.290
KLH15-040E	15	1/2	12	11	27	27	27	7.5	37	57	49.5	69.5	M22×1.5	15	0.292
KLH16-030E	16	3/8	13	8	30	30	30	7.5	37	59	49.5	71.5	M24×1.5	15	0.382
KLH16-040E	16	1/2	13	11	30	30	30	7.5	38	59	49.5	71.5	M24×1.5	15	0.382
KLH18-040E	18	1/2	14	11	32	32	32	8	39	63	51.5	75.5	M26×1.5	15	0.450
KLH20-060E	20	3/4	16	16	36	36	36	8	40	65	51.5	77.5	M28×1.5	15	0.496
KLH22-040E	22	1/2	18	11	36	36	36	9	40	65	51.5	77.5	M30×1.5	15	0.571
KLH22-060E	22	3/4	18	16	36	36	36	9	40	65	51.5	77.5	M30×1.5	15	0.580
KLH25-060E	25	3/4	20	16	41	41	41	10	43	68	52.5	81.5	M35×1.5	15	0.844
KLH25-080E	25	1	20	21.5	46	41	41	10	48	68	52.5	81.5	M35×1.5	15	0.991
KLH28-060E	28	3/4	22	16	46	46	46	10	48	74	55	88	M38×1.5	15	1.121
KLH28-080E	28	1	22	21.5	46	46	46	10	48	74	55	88	M38×1.5	15	1.094
KLH30-060E	30	3/4	25	16	46	46	46	10	48	74	55.5	88.5	M40×1.5	15	1.071
KLH30-080E	30	1	25	21.5	46	46	46	10	51	74	55.5	88.5	M40×1.5	15	1.060

△注意：この形式の継手は障壁貫通を目的としたもので、強振動の発生する箇所、或いは接続ホースの圧力変動が大きい箇所では配管クランプ等、振動対策（継手に掛かる発生応力を軽減するため）が必要です。

注. 予告なしに、品質・性能・改善のため寸法を変更する事があります。

△CAUTION: This type of fitting is designed to be used for wall penetration. When used in the place of strong vibration and / or pressure fluctuation, proper vibration measures such as fixing the piping by clamp are required.

Note. Dimensions might be modified due to improvement of quality and performance.

ホース接続 隔壁ユニオン エルボ (めす)

Female Seat Hose Connection Bulkhead Elbow

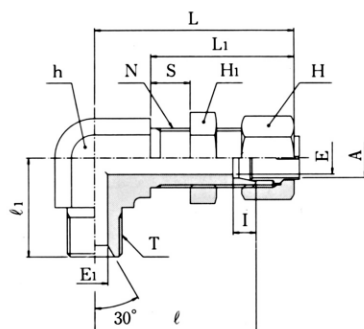

単位：mm/Unit: mm

継手の呼び Part No.	適用管 外径 Out. Dia. of Applied Pipe A	(G) T	E	E ₁	二面幅 Width across flats h	六角対辺 Hex Width H		I	ℓ ₁	ℓ	手締め(約) Fingertight Length (about)		N	最大 Max S	重量 Weight (kg)
						H ₁	H				L ₁	L			
KLS08-020E	8	1/4	6	5.5	19	19	17	7	26	46	42.5	56.5	M14×1.5	13	0.115
KLS08-030E	8	3/8	6	8	19	19	17	7	27	46	42.5	56.5	M14×1.5	13	0.116
KLS10-020E	10	1/4	8	5.5	22	22	19	7	28	48	43.5	59.5	M16×1.5	13	0.155
KLS10-030E	10	3/8	8	8	22	22	19	7	29	48	43.5	59.5	M16×1.5	13	0.158
KLS10-040E	10	1/2	8	11	24	22	19	7	33	49	43.5	60.5	M16×1.5	13	0.187
KLS12-020E	12	1/4	10	5.5	24	24	22	7	30	49	43.5	60.5	M18×1.5	13	0.194
KLS12-030E	12	3/8	10	8	24	24	22	7	30	49	43.5	60.5	M18×1.5	13	0.190
KLS12-040E	12	1/2	10	11	24	24	22	7	33	49	43.5	60.5	M18×1.5	13	0.190
KLS15-030E	15	3/8	12	8	27	27	27	7.5	33	57	49.5	69.5	M22×1.5	15	0.288
KLS15-040E	15	1/2	12	11	27	27	27	7.5	36	57	49.5	69.5	M22×1.5	15	0.294
KLS16-030E	16	3/8	13	8	30	30	30	7.5	34	59	49.5	71.5	M24×1.5	15	0.352
KLS16-040E	16	1/2	13	11	30	30	30	7.5	37	59	49.5	71.5	M24×1.5	15	0.386
KLS18-040E	18	1/2	14	11	32	32	32	8	37	63	51.5	75.5	M26×1.5	15	0.452
KLS20-060E	20	3/4	16	16	36	36	36	8	40	65	51.5	77.5	M28×1.5	15	0.495
KLS22-040E	22	1/2	18	11	36	36	36	9	40	65	51.5	77.5	M30×1.5	15	0.603
KLS22-060E	22	3/4	18	16	36	36	36	9	40	65	51.5	77.5	M30×1.5	15	0.596
KLS25-060E	25	3/4	20	16	41	41	41	10	43	68	52.5	81.5	M35×1.5	15	0.869
KLS25-080E	25	1	20	21.5	41	41	41	10	43	68	52.5	81.5	M35×1.5	15	0.864
KLS28-060E	28	3/4	22	16	46	46	46	10	48	74	55	88	M38×1.5	15	1.133
KLS28-080E	28	1	22	21.5	46	46	46	10	48	74	55	88	M38×1.5	15	1.127
KLS30-060E	30	3/4	25	16	46	46	46	10	48	74	55.5	88.5	M40×1.5	15	1.083
KLS30-080E	30	1	25	21.5	46	46	46	10	48	74	55.5	88.5	M40×1.5	15	1.058

△注意：この形式の継手は障壁貫通を目的としたもので、強振動の発生する個所、或いは接続ホースの圧力変動が大きい個所では配管クランプ等、振動対策（継手に掛かる発生応力を軽減するため）が必要です。

注. 予告なしに、品質・性能・改善のため寸法を変更する事があります。

△CAUTION: This type of fitting is designed to be used for wall penetration. When used in the place of strong vibration and / or pressure fluctuation, proper vibration measures such as fixing the piping by clamp are required.

Note. Dimensions might be modified due to improvement of quality and performance.

ホース接続 ティー片ニップル (めす)

Female Seat Hose Connection Run Tee

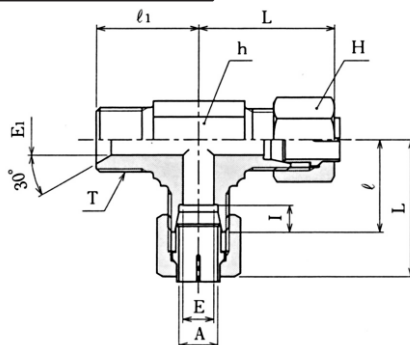

単位：mm/Unit: mm

継手の呼び Part No.	適用管外径 Out. Dia. of Applied Pipe A	(G) T	E	E ₁	二面幅 Width across flats h	六角対辺 Hex Width H	I	l ₁	ℓ	手締め(約) Fingertight Length (about) L	重量 Weight (kg)
KTG08-020E	8	1/4	6	5.5	17	17	7	25	23	33.5	0.109
KTG10-020E	10	1/4	8	5.5	19	19	7	26	24	35.5	0.138
KTG10-030E	10	3/8	8	8	19	19	7	27	24	35.5	0.142
KTG12-020E	12	1/4	10	5.5	19	22	7	26	24	35.5	0.147
KTG12-030E	12	3/8	10	8	19	22	7	27	24	35.5	0.152
KTG15-030E	15	3/8	12	8	24	27	7.5	30	29	41.5	0.259
KTG15-040E	15	1/2	12	11	24	27	7.5	33	29	41.5	0.270
KTG16-030E	16	3/8	13	8	27	30	7.5	33	32	44.5	0.360
KTG16-040E	16	1/2	13	11	27	30	7.5	36	32	44.5	0.361
KTG18-040E	18	1/2	14	11	27	32	8	36	32	44.5	0.354
KTG20-040E	20	1/2	17	11	30	36	8	38	33	45.5	0.480
KTG20-060E	20	3/4	17	16	30	36	8	38	33	45.5	0.440
KTG22-040E	22	1/2	18	11	32	36	9	38	34	46.5	0.430
KTG22-060E	22	3/4	18	16	32	36	9	39	34	46.5	0.434
KTG25-080E	25	1	20	21.5	36	41	10	43	36	49.5	0.760

注. 予告なしに、品質・性能・改善のため寸法を変更する事があります。

Note. Dimensions might be modified due to improvement of quality and performance.

ホース接続 ティー片ニップル

Male Seat Hose Connection Run Tee

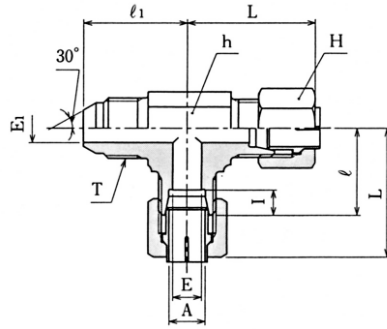

単位 : mm / Unit: mm

継手の呼び Part No.	適用管外径 Out. Dia. of Applied Pipe A	(G) T	E	E ₁	二面幅 Width across flats h	六角対辺 Hex Width H	I	ℓ ₁	ℓ	手締め(約) Fingertight Length (about) L	重量 Weight (kg)
KTJ08-020E	8	1/4	5	5.5	17	17	7	26	23	33.5	0.109
KTJ10-020E	10	1/4	8	5.5	19	19	7	27	24	35.5	0.138
KTJ10-030E	10	3/8	8	8	19	19	7	29	24	35.5	0.146
KTJ12-020E	12	1/4	10	5.5	19	22	7	27	24	35.5	0.147
KTJ12-030E	12	3/8	10	8	19	22	7	29	24	35.5	0.156
KTJ15-030E	15	3/8	12	8	24	27	7.5	33	29	41.5	0.263
KTJ15-040E	15	1/2	12	11	24	27	7.5	34	29	41.5	0.276
KTJ16-030E	16	3/8	13	8	27	30	7.5	36	32	44.5	0.364
KTJ16-040E	16	1/2	13	11	27	30	7.5	38	32	44.5	0.367
KTJ18-040E	18	1/2	14	11	27	32	8	38	32	44.5	0.360
KTJ20-040E	20	1/2	17	11	30	36	8	40	33	45.5	0.484
KTJ20-060E	20	3/4	17	16	30	36	8	41	33	45.5	0.444
KTJ22-040E	22	1/2	18	11	32	36	9	40	34	46.5	0.436
KTJ22-060E	22	3/4	18	16	32	36	9	42	34	46.5	0.438
KTJ25-080E	25	1	20	21.5	36	41	10	46	36	49.5	0.769

注. 予告なしに、品質・性能・改善のため寸法を変更する事があります。

Note. Dimensions might be modified due to improvement of quality and performance.

ホース接続 ティー中ニップル (めす)

Female Seat Hose Connection Branch Tee

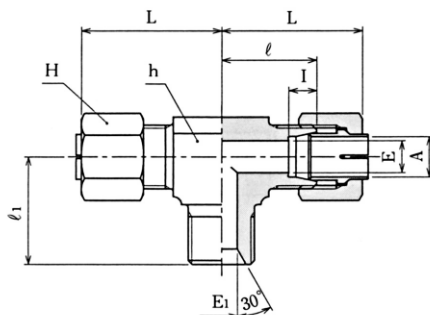

単位 : mm / Unit: mm

継手の呼び Part No.	適用管外径 Out. Dia. of Applied Pipe A	(G) T	E	E ₁	二面幅 Width across flats h	六角対辺 Hex Width H	I	l ₁	l	手締め(約) Fingertight Length (about) L	重量 Weight (kg)
KTE08-020E	8	1/4	6	5.5	17	17	7	26	23	33.5	0.110
KTE10-020E	10	1/4	8	5.5	19	19	7	26	24	35.5	0.141
KTE10-030E	10	3/8	8	8	19	19	7	27	24	35.5	0.145
KTE12-020E	12	1/4	10	5.5	19	22	7	26	24	35.5	0.154
KTE12-030E	12	3/8	10	8	19	22	7	27	24	35.5	0.157
KTE15-030E	15	3/8	12	8	24	27	7.5	30	29	41.5	0.265
KTE15-040E	15	1/2	12	11	24	27	7.5	33	29	41.5	0.276
KTE16-030E	16	3/8	13	8	27	30	7.5	33	32	44.5	0.363
KTE16-040E	16	1/2	13	11	27	30	7.5	36	32	44.5	0.370
KTE18-040E	18	1/2	14	11	27	32	8	36	32	44.5	0.378
KTE20-040E	20	1/2	17	11	30	36	8	38	33	45.5	0.484
KTE20-060E	20	3/4	17	16	30	36	8	38	33	45.5	0.454
KTE22-040E	22	1/2	18	11	32	36	9	38	34	46.5	0.457
KTE22-060E	22	3/4	18	16	32	36	9	39	34	46.5	0.455
KTE25-080E	25	1	20	21.5	36	41	10	43	36	49.5	0.782

注. 予告なしに、品質・性能・改善のため寸法を変更する事があります。

Note. Dimensions might be modified due to improvement of quality and performance.

ホース接続 ティー中ニップル (おす)

Male Seat Hose Connection Branch Tee

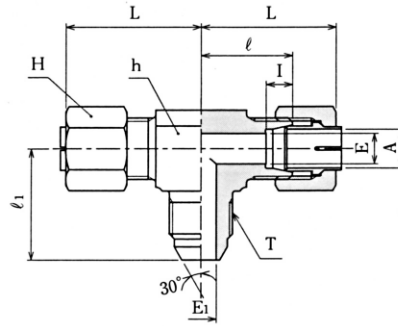

単位 : mm / Unit: mm

継手の呼び Part No.	適用管外径 Out. Dia. of Applied Pipe A	(G) T	E	E ₁	二面幅 Width across flats h	六角対辺 Hex Width H	I	ℓ ₁	ℓ	手締め(約) Fingertight Length (about) L	重量 Weight (kg)
KTD08-020E	8	1/4	6	5.5	17	17	7	25	23	33.5	0.110
KTD10-020E	10	1/4	8	5.5	19	19	7	27	24	35.5	0.141
KTD10-030E	10	3/8	8	8	19	19	7	29	24	35.5	0.149
KTD12-020E	12	1/4	10	5.5	19	22	7	27	24	35.5	0.154
KTD12-030E	12	3/8	10	8	19	22	7	29	24	35.5	0.161
KTD15-030E	15	3/8	12	8	24	27	7.5	33	29	41.5	0.269
KTD15-040E	15	1/2	12	11	24	27	7.5	34	29	41.5	0.282
KTD16-030E	16	3/8	13	8	27	30	7.5	36	32	44.5	0.367
KTD16-040E	16	1/2	13	11	27	30	7.5	38	32	44.5	0.376
KTD18-040E	18	1/2	14	11	27	32	8	38	32	44.5	0.384
KTD20-040E	20	1/2	17	11	30	36	8	40	33	45.5	0.488
KTD20-060E	20	3/4	17	16	30	36	8	41	33	45.5	0.458
KTD22-040E	22	1/2	18	11	32	36	9	40	34	46.5	0.463
KTD22-060E	22	3/4	18	16	32	36	9	42	34	46.5	0.459
KTD25-080E	25	1	20	21.5	36	41	10	46	36	49.5	0.791

注. 予告なしに、品質・性能・改善のため寸法を変更する事があります。

Note. Dimensions might be modified due to improvement of quality and performance.

ホース接続エルボ (めす)

Female Seat Hose Connection Elbow

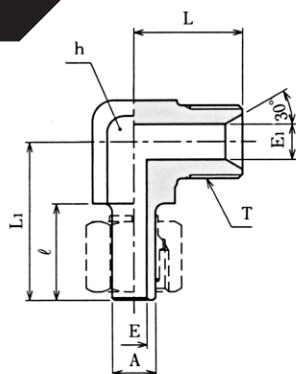

単位：mm / Unit: mm

継手の呼び Part No.	適用管外径 Out. Dia. of Applied Pipe A	(G) T	E	E ₁	二面幅 Width across flats h	ℓ	L	L ₁	重量 Weight (kg)
HLE08-020E	8	1/4	5	5.5	17	21	22	33	0.059
HLE10-020E	10	1/4	6	5.5	17	22	22	35	0.067
HLE10-030E	10	3/8	6	8	19	22	25	36	0.075
HLE10-040E	10	1/2	6	11	24	22	30	39	0.154
HLE12-020E	12	1/4	8	5.5	17	22.5	22	35	0.062
HLE12-030E	12	3/8	8	8	19	22.5	25	36	0.074
HLE12-040E	12	1/2	8	11	24	22.5	30	39	0.152
HLE16-030E	16	3/8	11	8	19	24.5	25	36	0.075
HLE16-040E	16	1/2	11	11	24	24.5	30	43	0.150
HLE20-040E	20	1/2	14	11	24	26	30	45	0.141
HLE20-060E	20	3/4	14	16	30	26	35	45	0.254
HLE25-060E	25	3/4	17	16	30	29.5	35	49	0.266
HLE25-080E	25	1	17	21.5	36	29.5	40	49	0.379
HLE30-080E	30	1	20	21.5	36	30.5	40	54	0.421
HLE30-100E	30	1 1/4	20	28	46	30.5	49	58	0.660

注. 予告なしに、品質・性能・改善のため寸法を変更する事があります。

Note. Dimensions might be modified due to improvement of quality and performance.

ホース接続エルボ (おす)

Male Seat Hose Connection Elbow

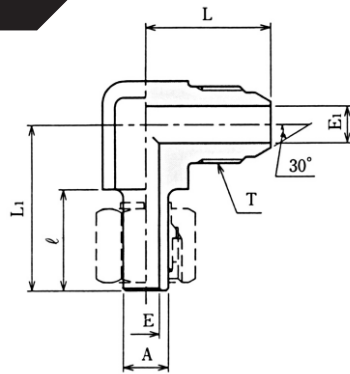

単位 : mm / Unit: mm

継手の呼び Part No.	適用管外径 Out. Dia. of Applied Pipe A	(G) T	E	E ₁	二面幅 Width across flats h	ℓ	L	L ₁	重量 Weight (kg)
HLD08-020E	8	1/4	5	5.5	17	21	24	33	0.059
HLD10-020E	10	1/4	6	5.5	17	22	24	35	0.067
HLD10-030E	10	3/8	6	8	19	22	27.5	36	0.079
HLD10-040E	10	1/2	6	11	24	22	32	39	0.160
HLD12-020E	12	1/4	8	5.5	17	22.5	24	35	0.062
HLD12-030E	12	3/8	8	8	19	22.5	27.5	36	0.078
HLD12-040E	12	1/2	8	11	24	22.5	32	39	0.158
HLD16-030E	16	3/8	11	8	19	24.5	28	43	0.079
HLD16-040E	16	1/2	11	11	24	24.5	32	43	0.156
HLD20-040E	20	1/2	14	11	24	26	32	45	0.147
HLD20-060E	20	3/4	14	16	30	26	36.5	45	0.258
HLD25-060E	25	3/4	17	16	30	29.5	36.5	49	0.270
HLD25-080E	25	1	17	21.5	36	29.5	40.5	49	0.388
HLD30-080E	30	1	20	21.5	36	30.5	40.4	54	0.430
HLD30-100E	30	1 1/4	20	28	46	30.5	50	58	0.670

注. 予告なしに、品質・性能・改善のため寸法を変更する事があります。

Note. Dimensions might be modified due to improvement of quality and performance.

ナット

NUT

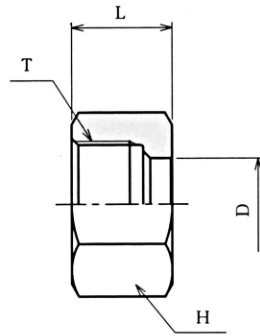

単位：mm/Unit: mm

継手の呼び Part No.	適用管外径 Out. Dia. of Applied Pipe 呼び径 Nominal sizes	外径 Out. Dia.	D	T	六角対辺 Hex Width H	L	重量 Weight (kg)
※KKN04-000N	4	4	4	M10×1.25	12	10.5	0.006
KKN06-000E	6	7.3	7.3	M12×1.5	14	15	0.010
KKN08-000E	8	9.3	9.3	M14×1.5	17	15	0.015
KKN10-000E	10	11.3	11.3	M16×1.5	19	16	0.019
KKN12-000E	12	13.3	13.3	M18×1.5	22	16	0.026
KKN15-000E	15	16.3	16.3	M22×1.5	27	19	0.045
KKN16-000E	16	17.3	17.3	M24×1.5	30	19	0.061
KKN18-000E	18	19.5	19.5	M26×1.5	32	19	0.063
KKN20-000E	20	21.7	21.7	M28×1.5	36	19	0.071
KKN22-000E	22	23.7	23.7	M30×1.5	36	19	0.072
KKN25-000E	25	26.7	26.7	M35×1.5	41	20	0.102
KKN28-000E	28	29.8	29.8	M38×1.5	46	21	0.142
KKN30-000E	30	31.8	31.8	M40×1.5	46	22	0.130
KKN35-000E	35	37	37	M45×1.5	55	25	0.223
※KKN38-000N	38	38	38	M48×1.5	60	27	0.330
※KKN40-000N	40	40	40	M52×2	60	29.5	0.303
※KKN42-000N	42	42	42	M52×2	60	29.5	0.294
※KKN50-000N	50	50	50	M64×2	75	31.5	0.532
※KKN11-000N	1/8	10.5	10.5	M16×1.5	19	16	0.019
※KKN13-000N	1/4	13.8	13.8	M20×1.5	24	18	0.035
※KKN17-000N	3/8	17.3	17.3	M26×1.5	32	19	0.065
※KKN21-000N	1/2	21.7	21.7	M30×1.5	36	19	0.080
※KKN27-000N	3/4	27.2	27.2	M38×1.5	46	21	0.147
※KKN34-000N	1	34.0	34.0	M45×1.5	55	25	0.245
※KKN43-000N	1 1/4	42.7	42.7	M56×2	65	30.5	0.379
※KKN48-000N	1 1/2	48.6	48.6	M64×2	75	31.5	0.539

注. 1. エンベロープ付スリーブ用ナット(※印表示のないもの)は、ナット端面に下図の識別表示をしております。(35ミリサイズを除く)
2. 予告なしに、品質・性能・改善のため寸法を変更する事があります。

⚠警告：エンベロープ付スリーブ用ナット及びエンベロープ付スリーブ(※印表示のないもの)は、従来のNS形スリーブ及びナットと合わせて使用しないでください。

Note. 1. The nut for enveloped sleeve is marked as below. (Except φ35)
2. Dimensions might be modified due to improvement of quality and performance.

⚠CAUTION: Do not mix enveloped sleeve (without ※mark) and nut for enveloped sleeve with the sleeve and nut of conventional NS Type.

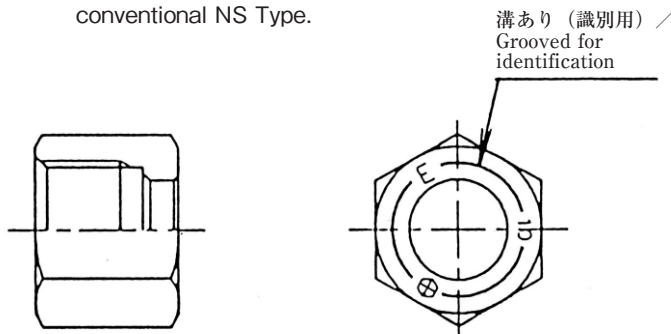

エンベロープ付スリーブ用ナットの識別標示 / Marking of the nut for enveloped sleeve

スリーブ

SLEEVE

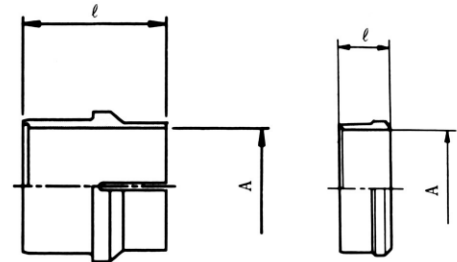

※印サイズの形状
※Shape of ※marked

単位：mm/Unit: mm

継手の呼び Part No.	適用管外径 Out. Dia. of Applied Pipe 呼び径 Nominal sizes	外径 Out. Dia.	l	重量 Weight (kg)
※KK004-000N	4	4	7	0.001
KK006-000E	6	7.3	14	0.002
KK008-000E	8	9.3	14	0.003
KK010-000E	10	11.3	15	0.004
KK012-000E	12	13.3	15	0.004
KK015-000E	15	16.3	16	0.005
KK016-000E	16	17.3	16	0.006
KK018-000E	18	19.5	16.5	0.007
KK020-000E	20	21.7	16.5	0.009
KK022-000E	22	23.7	16.5	0.010
KK025-000E	25	26.7	18.3	0.013
KK028-000E	28	29.8	18.3	0.014
KK030-000E	30	31.8	19	0.017
KK035-000E	35	37	22	0.021
※KK038-000N	38	38	14	0.018
※KK040-000N	40	40	14	0.017
※KK042-000N	42	42	14	0.018
※KK050-000N	50	50	14	0.022
※KK011-000N	1/8	10.5	10	0.003
※KK013-000N	1/4	13.8	10	0.004
※KK017-000N	3/8	17.3	10	0.005
※KK021-000N	1/2	21.7	10	0.006
※KK027-000N	3/4	27.2	11	0.010
※KK034-000N	1	34.0	14	0.015
※KK043-000N	1 1/4	42.7	14	0.021
※KK048-000N	1 1/2	48.6	14	0.025

締付治具

HAND PRESETTING TOOL

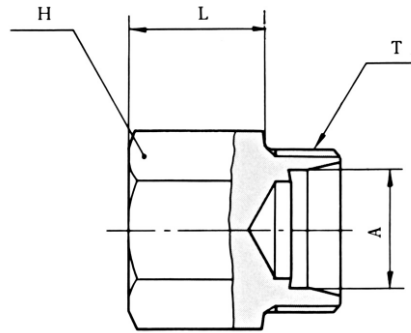

単位：mm/Unit: mm

継手の呼び Part No.	適用管外径 Out. Dia. of Applied Pipe A		L	H	T	重量 Weight (kg)
	呼び径 Nominal sizes	外径 Out. Dia.				
PJA06-000E	6		40	17	M12×1.5	0.087
PJA08-000E	8		40	17	M14×1.5	0.090
PJA10-000E	10		40	17	M16×1.5	0.092
PJA12-000E	12		40	27	M18×1.5	0.230
PJA15-000E	15		40	27	M22×1.5	0.228
PJA16-000E	16		40	27	M24×1.5	0.240
PJA18-000E	18		40	27	M26×1.5	0.250
PJA20-000E	20		40	41	M28×1.5	0.490
PJA22-000E	22		40	41	M30×1.5	0.515
PJA25-000E	25		40	41	M35×1.5	0.524
PJA28-000E	28		40	41	M38×1.5	0.545
PJA30-000E	30		40	41	M40×1.5	0.554
PJA35-000E	35		40	55	M45×1.5	0.890
PJA38-000N	38		50	55	M48×1.5	1.080
PJA40-000N	40		50	55	M52×2	1.180
PJA42-000N	42		50	55	M52×2	1.120
PJA50-000N	50		50	65	M64×2	1.640
PJA11-000N	1/8	10.5	40	17	M16×1.5	0.089
PJA13-000N	1/4	13.8	40	27	M20×1.5	0.224
PJA17-000N	3/8	17.3	40	27	M26×1.5	0.241
PJA21-000N	1/2	21.7	40	41	M30×1.5	0.508
PJA27-000N	3/4	27.2	40	41	M38×1.5	0.540
PJA34-000N	1	34.0	40	55	M45×1.5	0.900
PJA43-000N	1 1/4	42.7	50	65	M56×2	1.610
PJA48-000N	1 1/2	48.6	50	65	M64×2	1.650

注. 予告なしに、品質・性能・改善のため寸法を変更する事があります。

Note. Dimensions might be modified due to improvement of quality and performance.

銅ガスケット

Copper Gasket

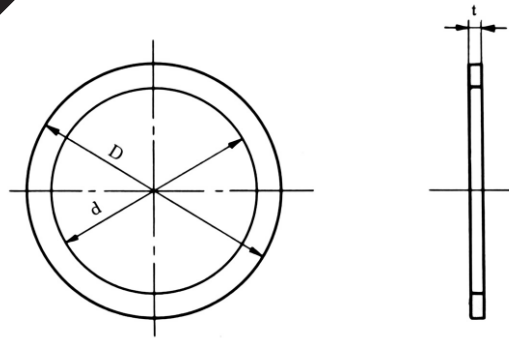

単位：mm/Unit: mm

継手の呼び Part No.	対応ねじ Corresponding thread	d	D	t
KP-A-01	G 1/8	10	18	2
KP-A-03	G 1/4	14	22	2
KP-A-05	G 3/8	17	26	2
KP-A-07	G 1/2	21.5	32	2
KP-A-11	G 3/4	27	38	2
KP-A-16	G 1	34	42	2
KP-A-20	G 1 1/4	43	53	2
KP-A-23	G 1 1/2	49	60	2
KP-A-28	G 2	61	72	2

注. 材質はりん脱酸銅

Note. Material: Copper phosphate

ボンデットシール

Bonded Seal

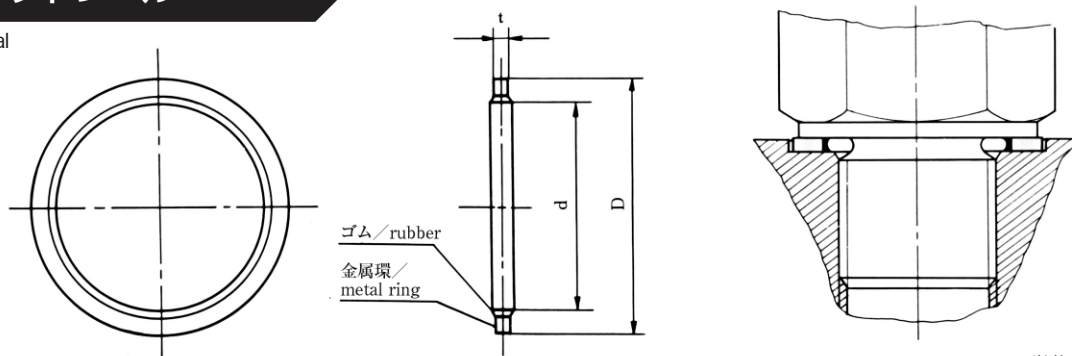

単位：mm/Unit: mm

継手の呼び Part No.	対応ねじ Corresponding thread	d	D	t
KP-C-01	G 1/8	9.9	17	2
KP-C-02	G 1/4	13.3	20.5	2
KP-C-03	G 3/8	16.8	24	2
KP-C-04	G 1/2	21.1	29	2
KP-C-05	G 3/4	26.6	34.5	2
KP-C-06	G 1	33.4	41.5	2.3
KP-C-07	G 1 1/4	42.1	50.5	2.3
KP-C-08	G 1 1/2	48.0	57	2.3
KP-C-09	G 2	59.8	69	2.3

注.1.ゴム材質はNBR、金属環はJWG3141のSPCC（冷間圧延鋼板）を標準仕様としております。

（使用温度-20℃～120℃）

2. 予告なしに、品質・性能・改善のため寸法を変更する事があります。

Note. 1. Material of rubber is NBR and metal ring is JWG3141 (cold rolled plate) as standard.

(range of working temperature: -20℃～120℃)

2. Dimensions might be modified due to improvement of quality and performance.

平行ねじ形式の相手ポートの形状・寸法および適用するガスケット

Shape, dimension and applicable gasket for the mating port of straight thread type

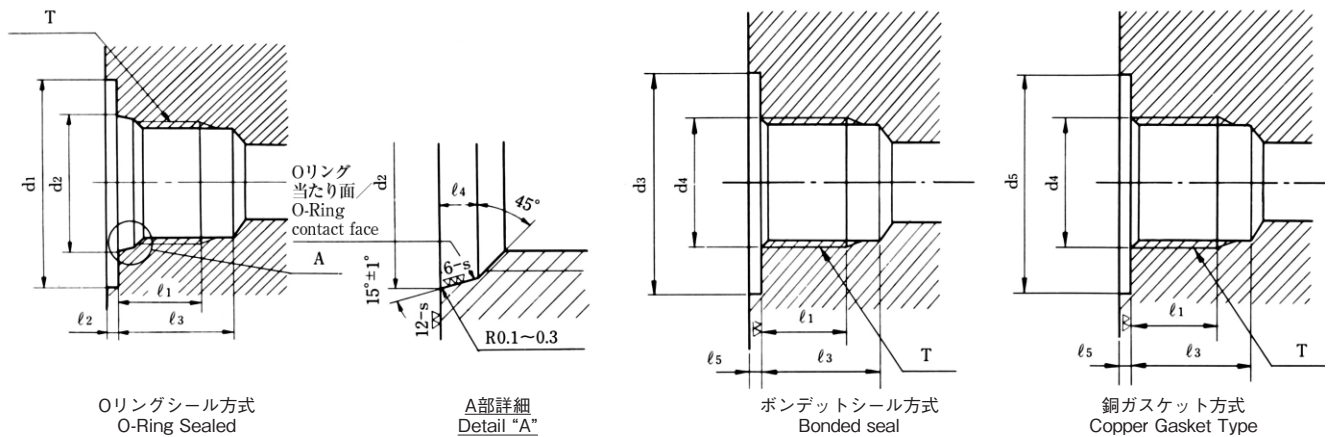

単位：mm/Unit: mm

T	d ₁	d ₂ + ₀ ^{+0.1}	d ₃ + ₀ ^{+0.3}	(最大) (Max) d ₄	d ₅ + ₀ ^{+0.3}	(最小) (Min) l ₁	(最大) (Max) l ₂	(最小) (Min) l ₃	l ₄ + ₀ ^{+0.4}	l ₅	備考 Remarks
G 1/8	18	11.6	17.4	9.7	18.2	10	1	15	2	1	
G 1/4	24	15.6	20.9	13.1	22.2	14	1.5	20	2.5	1	
G 3/8	28	18.6	24.4	16.6	26.2	14	2	20	2.5	1	
G 1/2	34	22.6	29.4	20.9	32.2	17	2.5	25	2.5	1	
※ G 3/4	45	30.5	34.9	26.4	38.2	19	2.5	27	3.5	1	
G 1	51	35.8	41.9	33.2	42.3	22	2.5	31	3.5	1	
G 1 1/4	62	44.8	50.9	41.9	53.3	24	2.5	33	3.5	1	
G 1 1/2	68	50.8	57.4	47.8	60.3	25	2.5	34	3.5	1	
G 2	76	67.2	69.4	59.6	72.3	29	2.5	38	5.5	1	

注. 接続ポート加工の際、次の点にご注意ください。

1. ねじGは、JIS B 0202の管用平行ねじとします。
2. Oリング当たり面は、軸方向のきずまたはらせん状のツールマークがあってはなりません。
3. d₁座ぐり面は、ねじの軸線に対して直角かつ平坦でなければなりません。
4. 座ぐりの深さl₂は注2、注3の規定が満足されれば零でも構いません。

Note. Pay attention to the following points when machining connection port.

1. Thread G shall be JIS B0202 (PT thread).
2. The face contacting an O-ring must have no flaws in the axial direction nor tool marks in spiral pattern.
3. Spot facing surface d₁ must be flat and right angle to the axial line of the thread.
4. Depth l₂ of spot facing may be zero if the Note 2 and 3 are met.

T	Oリング O-Ring JIS B 2401	ボンデッドシール Bonded Seal	銅ガスケット Copper Gasket	備考 Remarks
G 1/8	P 8	KP-C-01	KP-A-01	
G 1/4	P11	KP-C-02	KP-A-03	
G 3/8	P14	KP-C-03	KP-A-05	
G 1/2	P18	KP-C-04	KP-A-07	
※ G 3/4	P24	KP-C-05	KP-A-11	
G 1	P29	KP-C-06	KP-A-16	
G 1 1/4	P38	KP-C-07	KP-A-20	
G 1 1/2	P44	KP-C-08	KP-A-23	
G 2	P56	KP-C-09	KP-A-28	

5. Oリングは、適用流体の種類によって材質を選択してください。
6. このカタログに掲載のOリングシール継手(継手の記号:KCO, KCG, KLO, KLG, KTO, KHB)のG_{3/4}平行ねじ部のOリング溝径及び適用するOリングは、1990年改正前のJIS B 2351の寸法を採用しております。このため、表中の※印G_{3/4}ポート入口径(d₂寸法)は、当社の推奨寸法のφ30.5となっており、これに適用するOリングサイズは改正前規格のP24となっております。尚、JIS B 2351-1990に規定されるポート入口径はφ29.8(新規格、旧規格共同)で適用するOリングサイズはP22.4となります。新JIS規格による継手を御使用の場合はポート入口寸法及び御使用のOリングに注意してください。
7. 予告なしに、品質・性能・改善のため寸法を変更する事があります。

5. Material of O-ring must be selected according to the type fluid used.
6. The dimension of O-ring for G_{3/4} PT in this catalogue (symbol of fitting: KCO, KCG, KLO, KLG, KTO, KGHB) is according to JIS B2351 before improved in a 1990. Port inlet diameter (d₂) of G_{3/4} (indicted with ※mark) is our recommended φ30.5 and size of O-ring is P-24. In case of using the fitting designed by new JIS, the dimensions of O-ring and port inlet must be carefully selected.
7. Dimensions might be modified due to improvement of quality and performance.

1 くい込み式チェック継手の特長／Features of Bite Type Check Fitting

くい込み式チェック継手は、「逆止め機構を内蔵したくい込み継手」で次のような特長があります。

Bite type check fitting is built in a non-return mechanism and its features are as below.

(1) 一体化構造でコンパクト／One complete and compact structure

写真で見られる通り、配管に不必要なねじ接続部・シール部のない一体形構造のため軽量・コンパクトです。

As shown in above photo, one complete light and compact structure without threaded connection and sealing port.

(2) 配管工数・コストの低減／

Less man-power and cost of piping work

管との接続はくい込み接続のため、配管時にねじ切り・溶接・フレア加工等が一切不要で、配管工数・配管コストが大幅に低減できます。

Connection of fitting with pipes is bite type. Accordingly threading, welding, flaring, etc. are not required.

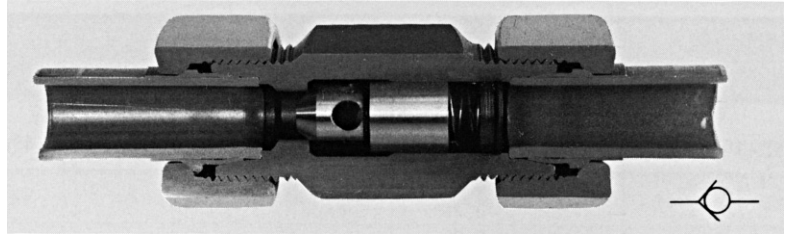

2 接続上の注意／Cautions on Connections

継手と管との接続は鋼管用くい込み継手の締付け手順に従ってください。なお、スリーブのプリセットには必ず締付治具（PJA）又は締付け装置（PSD）をご使用ください。

尚、継手内側への管の変形を防ぐため管の端面外周の面取りはCO.3以下としてください。

When connecting those check fittings to tube, follow the setting procedures of bite type tube fittings. In presetting the sleeve, be sure to use a hand presetting tool (PJA) or pre-setting device (PSD).

3 ご注文について／When ordering

ご注文の際は、管継手の呼び記号をご指示ください。

例えば、

When ordering, specify the part number code as below.

For example,

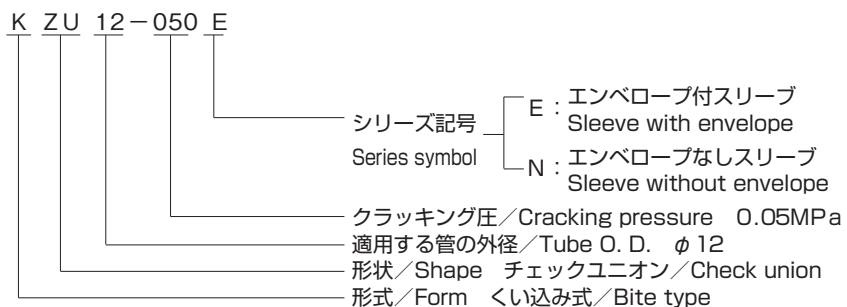

なおチェック コネクタ（KZC）の接続ねじは、64ページ各欄のねじを標準としております。

本カタログ記載以外（スローリターン用、クラッキング圧の変更、接続ねじサイズの変更等）のものも別途設計製作いたしますので、仕様をご明示の上お問い合わせください。

Furthermore, please inquire us if any other conditions (slow return, cracking pressure, connection threads, etc.) out of this catalogue will be necessary.

チェックユニオン

Check Union

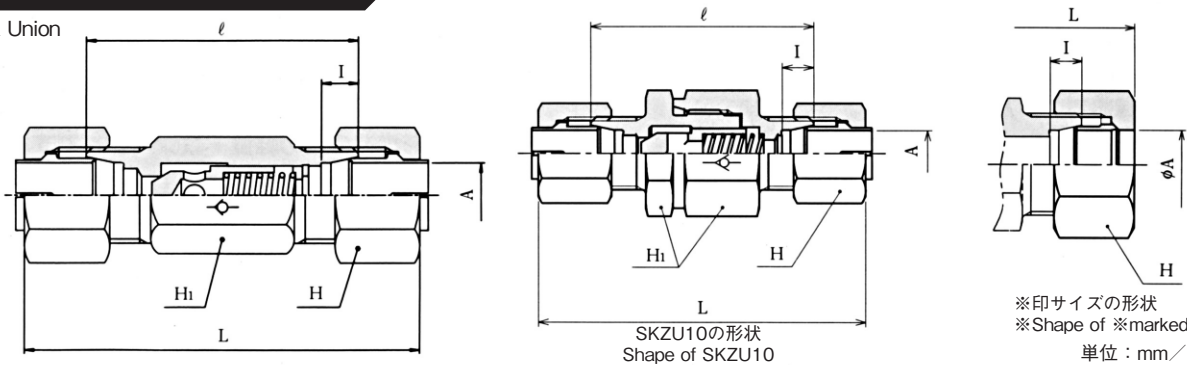

単位：mm/Unit: mm

継手の呼び Part No.	適用管外径 Out. Dia. of Applied Pipe A		定格流量 Flow Rate ℓ / min	クラッキング圧 Cracking Pressure MPa	六角対辺 Hex Width		I	ℓ	手締め(約) Fingertight Length (about) L	重量 Weight (kg)
	呼び径 Nominal sizes	外径 Out. Dia.			H ₁	H				
SKZU10-050E SKZU10-450E	10		18	0.05 0.45	24	19	7	49	72	0.140
KZU12-050E KZU12-450E	12		18	0.05 0.45	19	22	7	51	74	0.128
KZU15-050E KZU15-450E	15		30	0.05 0.45	24	27	7.5	58	83	0.222
KZU16-050E KZU16-450E	16		35	0.05 0.45	27	30	7.5	58	83	0.300
KZU18-050E KZU18-450E	18		45	0.05 0.45	27	32	8	63	88	0.312
KZU20-050E KZU20-450E	20		60	0.05 0.45	30	36	8	66	91	0.424
KZU22-050E KZU22-450E	22		70	0.05 0.45	32	36	9	72	97	0.440
KZU25-050E KZU25-450E	25		95	0.05 0.45	36	41	10	78	105	0.616
KZU28-050E KZU28-450E	28		120	0.05 0.45	41	46	10	83	111	0.832
KZU30-050E KZU30-450E	30		140	0.05 0.45	46	46	10	89	118	1.008
※KZU13-050N ※KZU13-450N	1/4	13.8	20	0.05 0.45	22	24	7.5	53	77	0.170
※KZU17-050N ※KZU17-450N	3/8	17.3	35	0.05 0.45	27	32	8	58	83	0.300
※KZU21-050N ※KZU21-450N	1/2	21.7	70	0.05 0.45	32	36	9	72	97	0.450
※KZU27-050N ※KZU27-450N	3/4	27.2	100	0.05 0.45	41	46	10	78	106	0.850

主な仕様/Main Specification

定格圧力/Rated Pressure

ϕ 10~25 :31MPa

ϕ 30 :28MPa

1/8B~3/4B :31MPa

使用流体/Service Fluid

一般油圧作動油/Hydraulic Oil

使用温度/Service Temperature

-20°C~120°C

定格流量/Flow Rate

上表をご参照ください。/Refer to table above

圧力損失/Pressure Loss

作動油粘度125 SSU (26cSt) における各流量に対する圧力損失は右図のとおりです。

Pressure loss Vs. flow rate under oil viscosity of 125 SSU (26cSt) is shown in right figure.

クラッキング圧/Cracking Pressure

0.05MPa (0.5kgf/cm²)、0.45MPa (4.5kgf/cm²) の2種類になっています。

The cracking pressure of 0.05MPa (0.5kgf/cm²) and 0.45MPa (4.5kgf/cm²) are available.

注.予告なしに、品質・性能・改善のため寸法を変更する事があります。

△注意:油圧作動油以外で御使用の場合は弊社にお問い合わせください。

Note. Dimensions might be modified due to improvement of quality and performance.

△CAUTION: Please inquire us when the fitting will be used excepting hydraulic oil.

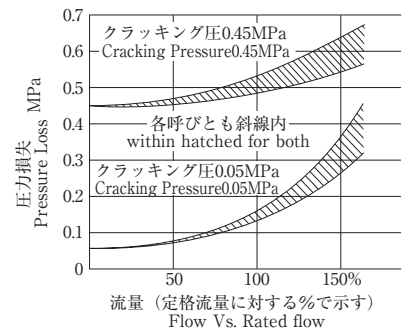

チェックエルボ

Check Elbow

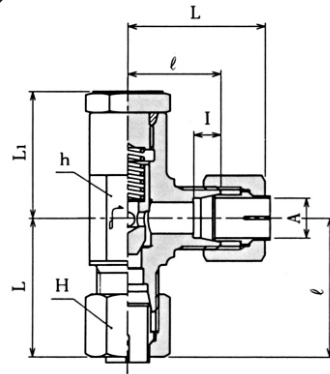

単位：mm/Unit: mm

継手の呼び Part No.	適用管外径 Out. Dia. of Applied Pipe A	定格流量 Flow Rate ℓ /min	クラッキング圧 Cracking Pressure MPa	二面幅 Width across flats h	六角対辺 Hex Width H	I	ℓ	L ₁	手締め(約) Fingertight Length (about) L	重量 Weight (kg)
KZL10-050E KZL10-450E	10	15	0.05 0.45	19	19	7	24	32	35.5	0.168
KZL12-050E KZL12-450E	12	18	0.05 0.45	19	22	7	24	32	35.5	0.178
KZL15-050E KZL15-450E	15	30	0.05 0.45	24	27	7.5	29	40	41.5	0.372
KZL16-050E KZL16-450E	16	35	0.05 0.45	27	30	7.5	32	40	44.5	0.430
KZL18-050E KZL18-450E	18	45	0.05 0.45	27	32	8	32	42	44.5	0.432
KZL20-050E KZL20-450E	20	60	0.05 0.45	30	36	8	33	45	45.5	0.574
KZL22-050E KZL22-450E	22	70	0.05 0.45	32	36	9	34	48	46.5	0.640
KZL25-050E KZL25-450E	25	95	0.05 0.45	36	41	10	36	52	49.5	0.696
KZL28-050E KZL28-450E	28	120	0.05 0.45	41	46	10	41	57	55	1.242
KZL30-050E KZL30-450E	30	140	0.05 0.45	46	46	10	46	65	60.5	1.518

主な仕様/Main Specification

定格圧力/Rate Pressure

φ10~25 :31MPa

φ30 :28MPa

1/8B~3/4B :31MPa

使用流体/Service Fluid

一般油圧作動油/Hydraulic Oil

使用温度/Service Temperature

-20°C~120°C

定格流量/Flow Rate

上表をご参照ください。/Refer to table above

圧力損失/Pressure Loss

作動油粘度125 SSU (26cSt) における各流量に対する圧力損失は右図のとおりです。

Pressure loss Vs. flow rate under oil viscosity of 125 SSU (26cSt) is shown in right figure.

クラッキング圧/Cracking Pressure

0.05MPa (0.5kgf/cm²)、0.45MPa (4.5kgf/cm²) の2種類になっています。

The cracking pressure of 0.05MPa (0.5kgf/cm²) and 0.45MPa (4.5kgf/cm²) are available.

注.予告なしに、品質・性能・改善のため寸法を変更する事があります。

△注意:油圧作動油以外で御使用の場合は弊社にお問い合わせください。

Note. Dimensions might be modified due to improvement of quality and performance.

△CAUTION: Please inquire us when the fitting will be used excepting hydraulic oil.

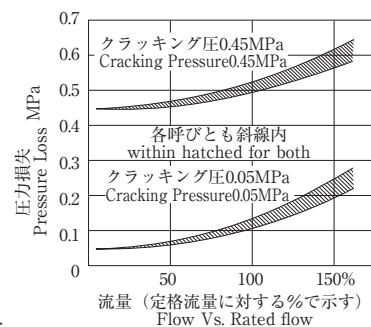

チェックコネクタ

Check Connector

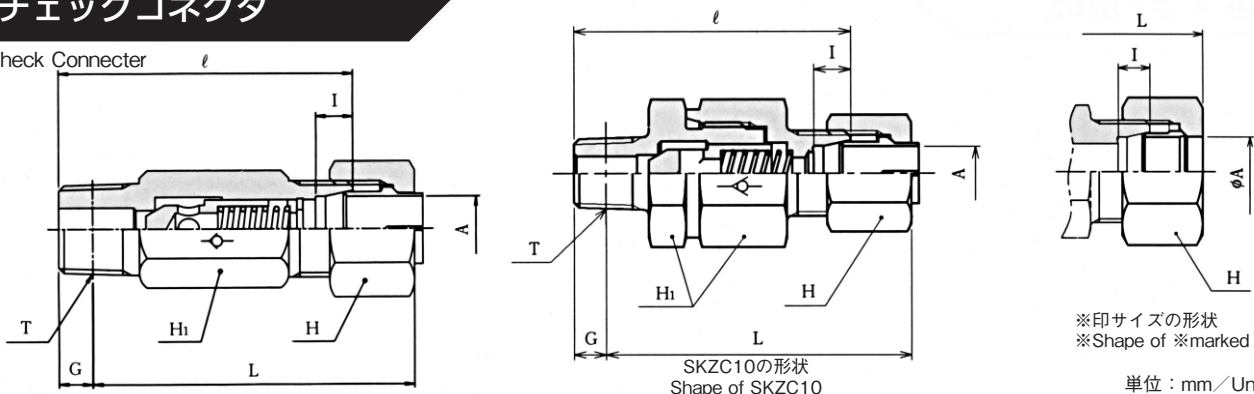

単位：mm/Unit: mm

継手の呼び Part No.	適用管外径 Out. Dia. of Applied Pipe A		定格流量 Flow Rate ℓ/min	クラッキング圧 Cracking Pressure MPa	(R) T	基準径の位置 Engagement Fingertight G	六角対辺 Hex Width		I	ℓ	手締め(約) Fingertight Length (about) L	重量 Weight (kg)
	呼び径 Nominal sizes	外径 Out. Dia.					H ₁	H				
SKZC10-050E SKZC10-450E	10		18	0.05 0.45	1/4	6.01	24	19	7	53	58.5	0.128
KZC12-050E KZC12-450E	12		18	0.05 0.45	3/8	6.35	19	22	7	55	60	0.110
KZC15-050E KZC15-450E	15		30	0.05 0.45	3/8	6.35	24	27	7.5	60	66	0.176
KZC16-050E KZC16-450E	16		35	0.05 0.45	1/2	8.16	27	30	7.5	64	68.5	0.243
KZC18-050E KZC18-450E	18		45	0.05 0.45	1/2	8.16	27	32	8	69	73.5	0.260
KZC20-050E KZC20-450E	20		60	0.05 0.45	3/4	9.53	30	36	8	75	78	0.363
KZC22-050E KZC22-450E	22		70	0.05 0.45	3/4	9.53	32	36	9	80	83	0.396
KZC25-050E KZC25-450E	25		95	0.05 0.45	1	10.39	36	41	10	87	90	0.568
KZC28-050E KZC28-450E	28		120	0.05 0.45	1	10.39	41	46	10	91	94.5	0.704
KZC30-050E KZC30-450E	30		140	0.05 0.45	1 1/4	12.70	46	46	10	100	102	0.980
※KZC13-050N ※KZC13-450N	1/4	13.8	20	0.05 0.45	3/8	6.35	22	24	7.5	56	61.5	0.145
※KZC17-050N ※KZC17-450N	3/8	17.3	35	0.05 0.45	1/2	8.16	27	32	8	64	68.5	0.255
※KZC21-050N ※KZC21-450N	1/2	21.7	70	0.05 0.45	3/4	9.53	32	36	9	80	83	0.391
※KZC27-050N ※KZC27-450N	3/4	27.2	100	0.05 0.45	1	10.39	41	46	10	87	90.5	0.734

主な仕様/Main Specification

定格圧力/Rate Pressure

φ10~25 :31MPa

φ30 :28MPa

1/2B~3/4B :31MPa

使用流体/Service Fluid

一般油圧作動油/Hydraulic Oil

使用温度/Service Temperature

-20°C~120°C

定格流量/Flow Rate

上表をご参照ください。/Refer to table above

圧力損失/Pressure Loss

作動油粘度125 SSU (26cSt) における各流量に対する圧力損失は右図のとおりです。

Pressure loss Vs. flow rate under oil viscosity of 125 SSU (26cSt) is shown in right figure.

クラッキング圧/Cracking Pressure

0.05MPa (0.5kgf/cm²)、0.45MPa (4.5kgf/cm²) の2種類になっています。

The cracking pressure of 0.05MPa (0.5kgf/cm²) and 0.45MPa (4.5kgf/cm²) are available.

注.予告なしに、品質・性能・改善のため寸法を変更する事があります。

△注意:油圧作動油以外で御使用の場合は弊社にお問い合わせください。

Note. Dimensions might be modified due to improvement of quality and performance.

△CAUTION: Please inquire us when the fitting will be used excepting hydraulic oil.

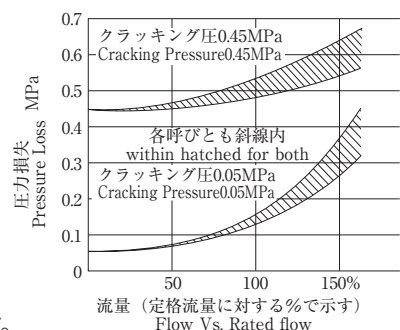

可変式絞り継手

Orifice Adjustable Fitting

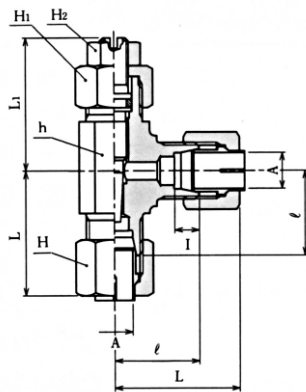

単位：mm / Unit: mm

継手の呼び Part No.	適用管外径 Out. Dia. of Applied Pipe A	二面幅 Width across flats h	六角対辺 Hex Width			I	ℓ	L ₁	手締め(約) Fingertight Length (about) L	重量 Weight (kg)
			H	H ₁	H ₂					
KTP10-000E	10	17	19	19	17	7	23	36	34.5	0.150
KTP12-000E	12	19	22	19	17	7	24	38	35.5	0.192

注. 予告なしに、品質・性能・改善のため寸法を変更する事があります。

Note. Dimensions might be modified due to improvement of quality and performance.

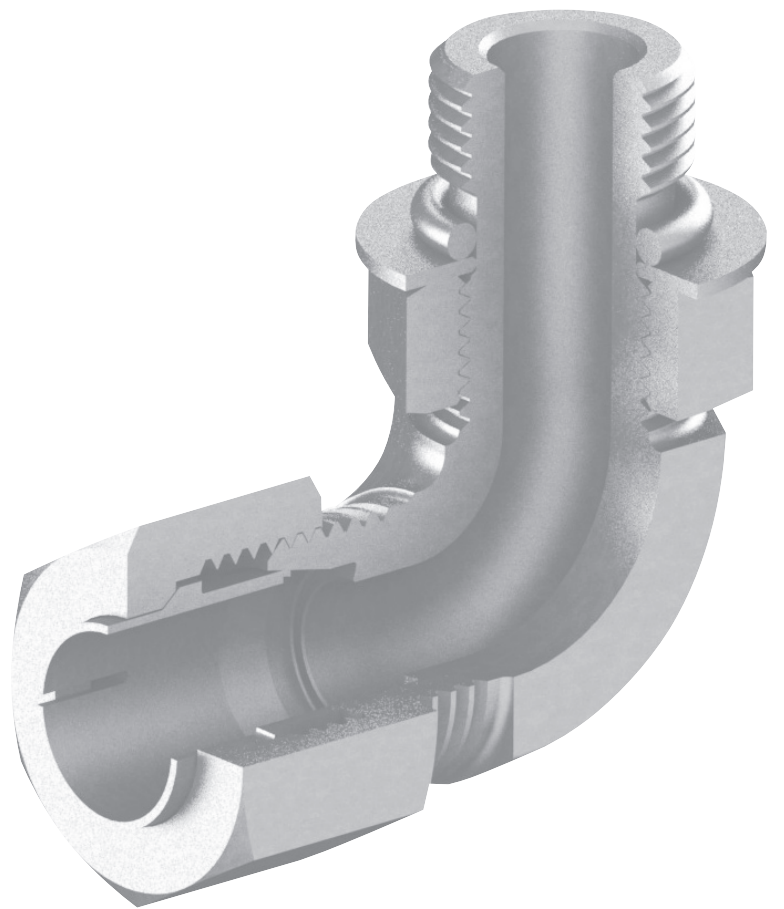

**注意**

継手、バルブ、関連するアクセサリーの不適切な選択又は取扱いは、人体やシステムに障害・損傷を与える恐れがあります。システム設計者及びユーザーの責任と権限による判断のもとに、使用されるシステムとの適合性や使用条件を考慮のうえ、継手、バルブ、関連するアクセサリーを選定し、適切な取り付け、操作及びメンテナンスを行って下さい。ご使用にあたり、取扱説明書をお読みいただき内容をよくご理解下さい。取扱説明書がお手元に無い場合及び不明な点はもよりの事業部営業部にお問い合わせ下さい。

**WARNING**

If you don't select and handle fittings, valves and related accessories in an adequate manner, it may damage human beings and applicable systems. Within the responsibility and authorization of users and piping designers, fittings, valves and related accessories shall be adequately selected, assembled, used and maintained based on the applicable conditions and product conformity to the system to be applied. Please read carefully our operation manual and feel free to contact with Ihara if you have any question or request.

製品保証期間について**1.保証期間**

当社製品の保証期間は、使用開始から1年以内、もしくは納入後1.5年以内、いずれか早期に到達する期間と致します。ただし、製品が特殊仕様である場合や当社の設計仕様を逸脱した状態で使用された場合は、この限りではありません。また、製品には耐久回数、交換部品などを定めているものがありますので、最寄の当社営業所にて御確認下さい。

2.保証範囲

保証期間中において当社の責による故障や損傷が明らかになった場合は、代替品又は必要な交換品を無償で提供致します。なお、ここでの保証は、当社製品単体の保証を意味するもので、当社製品の故障や損傷により誘発される損害は、保証の対象範囲から除外させていただきます。

Product Warranty**1.Warranty Period**

The warranty period of our products is one (1) year from putting into service or one and half (1.5) years after delivery whichever comes earlier. However, the products of special specification and/or the cases used under deviating from the specification shall be exempted. Please inquire us for the products that specify the service life or replacing parts.

2.Scope of Warranty

Any failure and damage under maker's responsibility will be found during the warranty period, the substitute and/or replacement parts shall be provided free of charge. The warranty shall not be extended to a claim for the liquidated damages.



ISO9001、ISO14001 認証事業所

ISO9001, ISO14001 Certified Office

イハラサイエンス株式会社**IHARA SCIENCE CORPORATION**

- ・東日本営業所／〒108-0074 東京都港区高輪3丁目11番3号 イハラ高輪ビル
TEL 03-6721-6981 (代) FAX 03-6721-6991
- ・中部営業所／〒460-0012 名古屋市中区千代田3丁目14番19号 (千代田ツカサビル)
TEL 052-323-2627 (代) FAX 052-323-2630
- ・西日本営業所／〒530-0044 大阪市北区東天満2丁目6番5号 (I・S南森町ビル)
TEL 06-6358-9255 (代) FAX 06-6358-9260

海外販売拠点

- 台湾：台中
- 中国：南通
- 韓国：ソウル
- 米国：カリフォルニア

■ URL: <http://www.ihara-sc.co.jp>

■ 本カタログの記載内容は、商品の改良等のため予告なく変更することがありますので、予めご了承下さい

■ The contents of this catalog are subject to change without notice due to improvement of products or other reasons.